

DEPARTMENT OF THE ARMY TECHNICAL MANUAL

TECHNICAL MANUAL

OPERATOR AND ORGANIZATIONAL

MAINTENANCE MANUAL

MIXER, CONCRETE, 4 WHEEL TRAILER MOUNTED,

GASOLINE ENGINE DRIVEN, NON TILT, 16 CU. FT.

(T. L. SMITH COMPANY MODEL 499A)

FSN 3895-444-1531

This copy is a reprint which includes current pages from Changes 1 and 2.

HEADQUARTERS, DEPARTMENT OF THE ARMY

7 JANUARY 1972

WARNING

FIRE HAZARD

Never fill the fuel tank while engine is in operation or hot to avoid the possibility of spilled fuel causing fire.

WARNING

DEATH DUE TO

CARBON MONOXIDE POISONING

May result if personnel fail to observe safety precautions. Never operate the engine in a closed building unless the exhaust is piped outside. The exhaust contains carbon monoxide, a poisonous odorless invisible gas, which if breathed, causes serious illness and possible death.

CHANGE }
 No. 2 }

HEADQUARTERS
 DEPARTMENT OF THE ARMY
 WASHINGTON, DC, 30 December 1980

**Operator and Organizational Maintenance Manual
 MIXER, CONCRETE, 4 WHEEL TRAILER
 MOUNTED, GASOLINE ENGINE DRIVEN,
 NON TILT, 16 CU. FT.
 (T. L. SMITH COMPANY MODEL 499A)
 NSN 3895-00 444-1531**

TM 5-3895-342-12, 7 January 1972, is changed as follows:

1. Remove old pages and insert new pages as indicated below. New or changed material is indicated by a vertical bar in the margin of the page.

<i>Remove pages</i>	<i>Insert Pages</i>
i and ii	i
1-1 and 1-2	1-1 and 1-2
3-1 and 3-2	3-1 and 3-2
None	3-2.1
4-3 and 4-4	4-3 and 4-4
4-11 and 4-12	4-11 and 4-12
None	4-25 and 4-26
A-1	A-1/(A-2 blank)
B-5 and B-6	B-5 and B-6
I-1 and I-2	I-1 and I-2

2. File this change in front of the publication for reference purposes.

By Order of the Secretary of the Army:

E. C. MEYER
General, United States Army
Chief of Staff

Official:

J. C. PENNINGTON
Major General, United States Army
The Adjutant General

Distribution:

To be distributed in accordance with DA Form 12-25B, Organizational maintenance requirements for Mixer, Concrete.

WARNING

NOISE HAZARD

Mixer may exceed noise level limitations when operating during cleaning cycle.

Use ear protectors.

Change 1 A/B blank

TECHNICAL MANUAL }
 NO. 5-3895-342-12 }

HEADQUARTERS
 DEPARTMENT OF THE ARMY
 WASHINGTON, DC, 7 January 1972

**OPERATOR AND ORGANIZATIONAL MANUAL
 MIXER, CONCRETE, 4 WHEEL TRAILER MOUNTED,
 GASOLINE ENGINE DRIVEN, NON TILT, 16 CU. FT.
 (T. L SMITH COMPANY MODEL 499A)
 NSN 3895-00-444-1531**

	Paragraph	Page
CHAPTER 1. INTRODUCTION		
Section I. General	1-1, 1-2	1-1
II. Description and Data	1-3	1-1
CHAPTER 2. OPERATING INSTRUCTIONS		
Section I. Service upon receipt of material	2-1, 2-2	2-1
II. Movement to a new work site	2-3, 2-4	2-2
III. Controls and instruments	2-5, 2-6	2-3
IV. Operation under usual conditions	2-7—2-10	2-4
V. Operation under unusual conditions	2-1—2-15	2-5
CHAPTER 3. OPERATOR/CREW MAINTENANCE INSTRUCTIONS		
Section I. Basic issue items.....	3-1	3-1
II. Lubrication instructions	3-2, 3-3	3-1
III. Preventive maintenance checks and services	3-4, 3-4.1	3-1
IV. Troubleshooting.....	3-5	3-3
V. Operator's maintenance.....	3-6—3-11	3-3
CHAPTER 4. ORGANIZATIONAL MAINTENANCE INSTRUCTIONS		
Section I. Service upon receipt of material	4-1	4-1
II. Repair parts, special tools and equipment	4-2, 4-3	4-3
III. Preventive maintenance checks and services	4-5, 4-5-1	4-3
IV. Troubleshooting.....	4-6	4-4
V. Radio interference suppression.....	4-7, 4-8	4-6
VI. Engine muffler, housing, flywheel, and valve tappets	4-10—4-14	4-7
VII. Upper and lower manifolds	4-15—4-17	4-9
VIII. Cooling system	4-18, 4-19	4-10
IX. Electrical system	4-20—4-26	4-11
X. Fuel system	4-27—4-32	4-15
XI. Lubrication system	4-33—4-36	4-18
XII. Engine control, meters, and gauges	4-37—4-45	4-19
XIII. Clutch assembly	4-46, 4-47	4-21
XIV. Water system	4-48—4-51	4-21
XV. Hoist cable	4-52	4-23
XVI. Hauling stub safety chain	4-53	4-23
XVII. Wheel assembly.....	4-54	4-25
CHAPTER 5. ADMINISTRATIVE STORAGE		
APPENDIX A. REFERENCES		A-1
B. MAINTENANCE ALLOCATION CHART		B-1
C. BASIC ISSUE ITEMS LIST AND ITEMS TROOP INSTALLED OR AUTHORIZED		C-1
INDEX		I-1

LIST OF ILLUSTRATIONS

Number	Title	Page
1-1	Concrete mixer left front $\frac{3}{4}$ view	1-2
1-2	Concrete mixer right rear $\frac{3}{4}$ view	1-3
1-3	Wiring diagram	1-5
2-1	Axle spring adjusting screw	2-1
2-2	Hauling stub	2-2
2-3	Skip hook	2-2
2-4	Water valve wrench retainer	2-2
2-5A	Engine gauges, meters and controls	2-3
2-5B	Master clutch	2-3
2-5C	Discharge spout hand wheel	2-3
2-5D	Skip controls	2-3
2-5E	Water gauge	2-3
2-5F	Water valve wrench	2-3
2-6	Magneto ground switch	2-4
2-7	Hand crank	2-4
3-1	Fuel tank service	3-3
3-2	Fuel strainer service	3-4
3-3	Oil filter breather service	3-4
3-4	Battery service	3-5
4-1	Drum drain plug	4-1
4-2	Water tank drain plug	4-1
4-3	Water pump drain plug	4-1
4-4	Engine crankcase drain plug	4-1
4-5	Belt guard removal	4-2
4-6	Hoist drive belts installation	4-2
4-7	Pump belt installation	4-2
4-8	Fire extinguisher installation	4-2
4-9A	Engine muffler, top canopy, side doors and front panel removal	4-7
4-9B	Front panel removal	4-7
4-10	Flywheel and flywheel shroud removal	4-8
4-11	Valve tappet cover	4-9
4-12	Valve tappet adjustment	4-9
4-13	Upper and lower manifolds removal	4-9
4-14	Cylinder air shrouds, exploded view	4-11
4-15	Batteries and cables removal	4-12
4-16A	Battery box removal	4-12
4-16B	Battery box removal	4-12
4-17	Starting motor removal	4-13
4-18	Magneto removal	4-13
4-19	Magneto contact points, replacement adjustment	4-14
4-20	Magneto timing	4-14
4-21	Spark plugs and leads removal	4-15
4-22	Hi-Temp safety switch and lead removal	4-15
4-23	Air cleaner removal	4-16
4-24	Air cleaner, oil cup removal	4-16
4-25	Fuel strainer removal	4-17
4-26	Carburetor removal.....	4-17
4-27	Fuel level sending unit removal	4-18
4-28	Fuel tank removal	4-18
4-29	Oil filter removal	4-18
4-30	Oil filler cap	4-19
4-31	Oil filler tube strainer removal	4-19
4-32	Choke control removal	4-19
4-33	Governor control removal	4-20
4-34	Meters and gauges removal.....	4-20
4-35	Clutch adjustment	4-21
4-36	Pump belt removal	4-22
4-37	Pump removal	4-22
4-38	Three-Way valve removal	4-22
4-39A	Hoist cable removal	4-23
4-39B	Hoist cable removal.....	4-23
4-40	Hauling stub safety chain removal	4-24

CHAPTER 1 INTRODUCTION

Section I. GENERAL

1-1. Scope

- a. These instructions are published for the use of the personnel to whom the mixer is issued. They provide information on the operation and organizational maintenance of the equipment.
- b. Appendix A contains a list of publications applicable to this manual. Appendix B contains the maintenance allocation chart. Appendix C contains the list of basic issue items list, items-troop installed or authorized.

1-2. Maintenance Forms and Records

- a. DA forms and procedures used for equipment maintenance will be only those prescribed by TM 38-750, The Army Maintenance Management System (TAMMS).
- b. Reporting Errors and Recommending Improvements. You can help improve this manual. If you find any mistakes or if you know of a way to improve the procedures, please let us know. Mail your letter or DA 2028 (Recommended Changes to Publications and Blank Forms) direct to: Commander, US Army Tank-Automotive Materiel Readiness Command, ATTN: DRSTA-MBP, Warren, MI 48090. A reply will be furnished to you.

Section II. DESCRIPTION AND DATA

1-3. Description

The concrete mixer, Model 499A (fig. 1-1 and 1-2) is a four wheel, portable mixer equipped with a four cylinder, air-cooled gasoline engine. The skip has a closed end with an arched cover plate for fast charging. The water tank is an automatic vertical siphon type with a gauge graduated in pounds and gallons. The skip clutch, skip brake, water controls, and discharge wheel are within arm's length of operator.

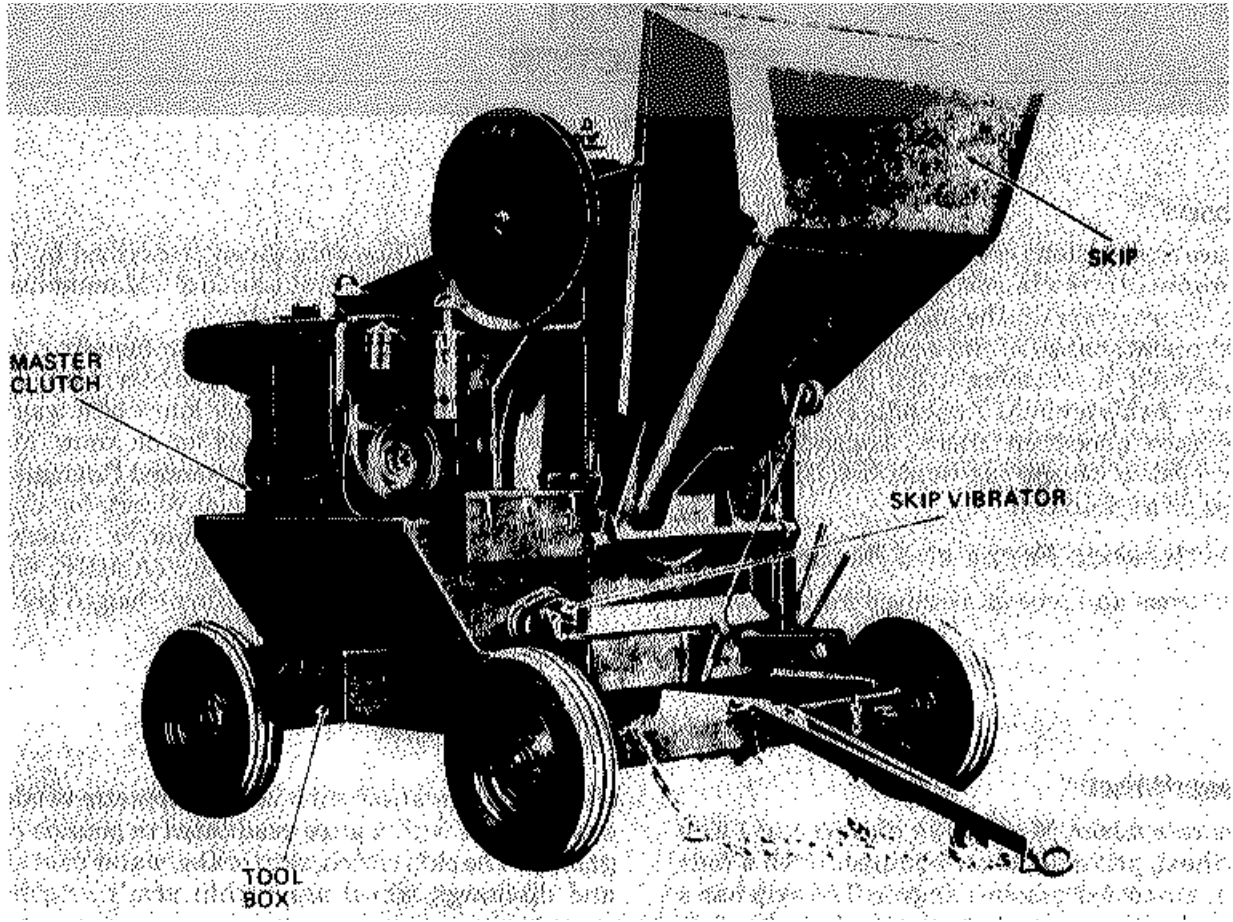

ME3895-342-12/1-1

Figure 1-1. Concrete mixer, left front three-quarter view.

Change 2 1-2

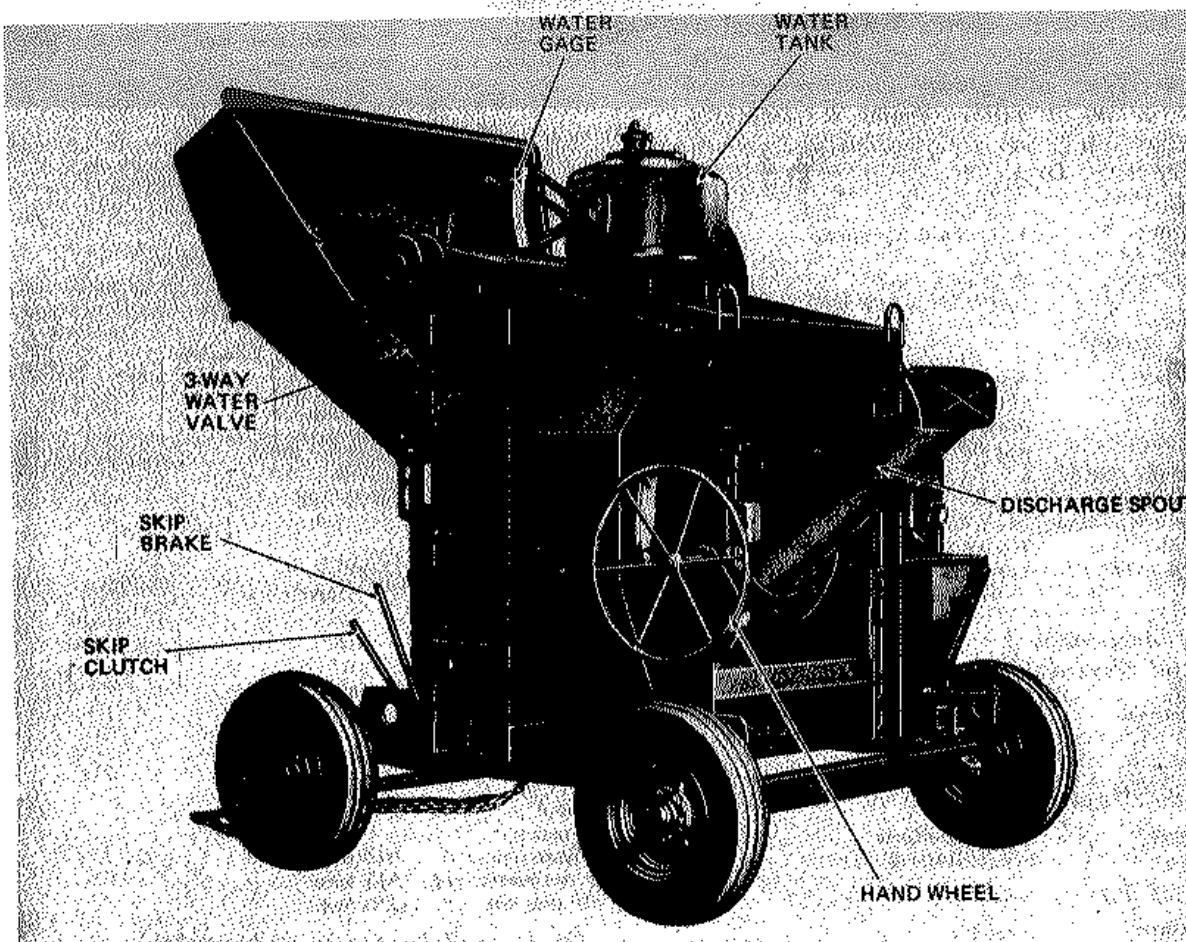

ME3895-342-12/1-2

Figure 1-2. Concrete mixer. Right rear three-quarter view.

1-4. Differences Between Models

This manual covers only the T. L. Smith Company Concrete Mixer, Model 499A. No differences exist within the serial number range covered in this manual. The serial number range covered in this manual is: 76900 to 77058.

1-5. Identification and Instruction Plates and Tabulated Data

a. Identification and Instruction Plates.

(1) *U. S. Army identification plate.* This plate is located on the rear motor support end. It gives the manufacturer, nomenclature, contract number, model and serial numbers, dimensions, federal stock number, weights, manufacturing date and warranty.

(2) *Transportation plate.* This plate is located on the rear motor support end. It gives nomenclature, dimensions, center of gravity, lifting lug and tie down lug locations.

(3) *Operating and lubrication instruction plate.* This plate is located on the rear motor support end. It gives general operating and lubrication instructions.

(4) *Water valve and skip control instruction plate.* This plate is located on the side of the mixer just to the left of the ladder. It shows lever positions for operating the water valve, the skip clutch and the brake.

(5) *Master clutch plate (for engine).* This plate is located on the engine belt guard. It shows lever positions for engaging the master clutch.

(6) Engine instruction and nameplate. This plate is located on the engine flywheel shroud. It gives engine manufacturer, model and serial numbers, types and grades of lubricant and gasoline to use at various engine temperatures, starting, stopping, and maintenance instructions.

b. Tabulated Data.

(1) *Mixer.*

Manufacturer T. L. Smith Company
 Model 499A
 Type Trailer mounted
 Capacity 16 Cu. Ft. (cubic feet)

(2) *Engine.*

Manufacturer Wisconsin Motor Corporation
 Model SPEC. #347756 MVF4D
 Type Air-cooled
 Ignition magneto
 Number of cylinders..... 4
 Bore and stroke 3¼-3¼ in. (inches)
 Displacement..... 107.7 cu. in. (cubic inches)
 Firing order 1-3-4-2
 Governed speed 1600 rpm (revolutions per minute at 19.2 hp.
 (horsepower)

(3) *Accessories.*

(a) *Governor.*

Manufacturer Wisconsin Motor Corporation
 Type centrifugal flyball
 Model T-84-H

(b) *Magneto.*

Manufacturer Fairbanks-Morse
 Type FM-ZVE4B7-4

(c) *Starting motor.*

Manufacturer Prestolite
 Model MBP-4018T
 Voltage rating 24 volts

(d) *Carburetor.*

Manufacturer Zenith
 Model 13206

(e) *Air cleaner.*

Manufacturer.....Donaldson Company
 Type.....oil bath

(g) *Oil filter.*

Manufacturer.....Fram Corporation
 TypeReplaceable element
 Model.....F-21-P

(4) *Clutch.*

Manufacturer..... Rockford Clutch Company
 Model CLA-1467-AF

(5) *Water pump.*

Manufacturer.....Carver Pump Company
 Model.....KF150

(6) *Hour meter-tachometer.*

Manufacturer.....Stewart-Warner
 Model567AS
 RPM1600

(7) *Capacities.*

Fuel tank..... 15 gallons
 Engine crankcase 3½ quarts
 Lubrication system with filter 5 quarts
 Tires..... 50 psi
 Reduction case 1 quart
 Water tank 26 gallons

(8) *Adjustment data.*

Valve tappet (intake).....008 inch (cold)
 Valve tappet (exhaust)016 inch (cold)
 Magneto contact gap015 inch
 Spark plug gap030 inch

(9) *Over-all dimensions and weights.*

Over-all length 110 inches
 over-all height 123 inches
 Over-all width 97 inches
 Weight 6, 500 pounds
 Shipping cubage 760 cubic feet
 Shipping weight

(10) *Wiring diagram.* See figure 1-3.

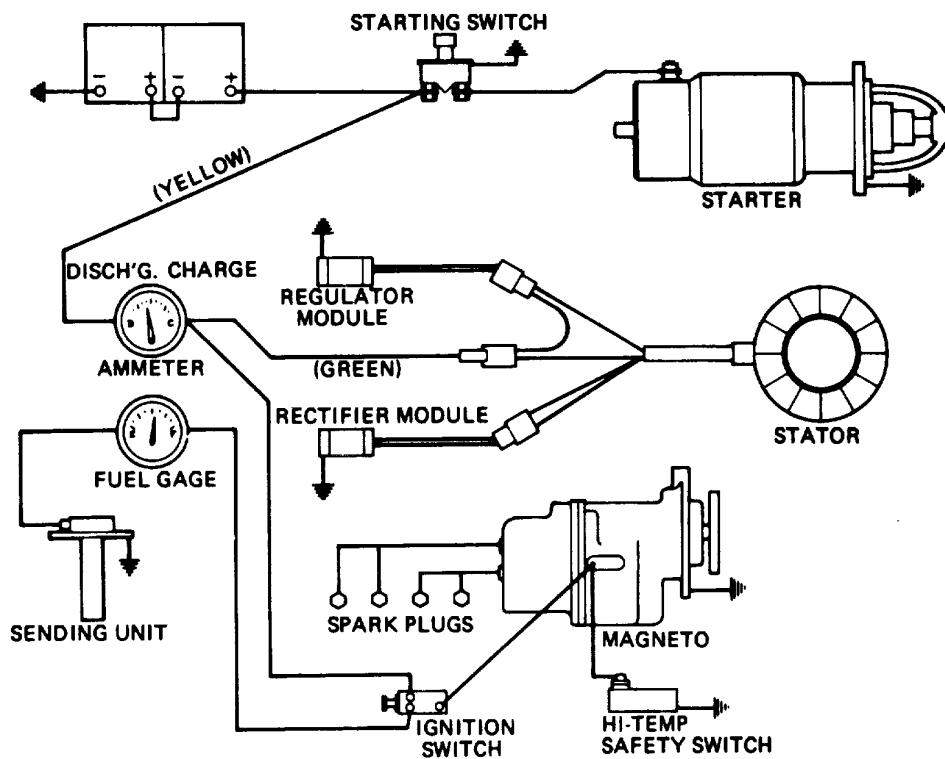

Figure 1-3. Wiring diagram.

ME3895-342-12/1-3

CHAPTER 2

OPERATING INSTRUCTIONS

Section I. SERVICE UPON RECEIPT OF MATERIAL

2-1. Inspecting and Servicing the Equipment

- a. Perform the following inspection and services upon receipt of equipment.
- (1) Inspect instruments and controls for damage.
 - (2) Inspect engine thoroughly for evidence of leaks and damaged or disconnected lines and wire.
 - (3) Inspect all hoses for damage and tight connections.
 - (4) Open fuel shutoff valve (fig. 3-2) by turning handle counter-clockwise as far as it will go.
 - (5) Clean around the oil and fuel filler caps before servicing to prevent entry of foreign matter.

WARNING

When filling fuel tank, do not smoke or use an open flame in the immediate area. Always provide a metal to metal contact between the fuel container and the fuel tank to prevent a spark being generated as fuel flows over metal surfaces.

- (6) Fill fuel tank, and perform lubrication services as instructed in the current lubrication order.

NOTE

When adding fuel to tank before initial operation, fill tank completely full to dilute the preservative in the tank to prevent clogging of the lines.

- b. Perform daily preventive maintenance checks and services. Refer to paragraph 3-4.

2-2. Setting Up Instructions

- a. *Spotting the Mixer on the Job.*

- (1) Position mixer so that it sets as level as possible. Locate the mixer convenient to the source of batch material and the area where the concrete will be used. Allow ample working space around the loading skip and discharge chute.
- (2) Tighten the adjusting screws at the end of each axle spring (fig. 2-1). This provides four-point K suspension to the frame and prevents frame torsions when raising the skip. Block the wheels to reduce vibration and to prevent movement of the mixer.

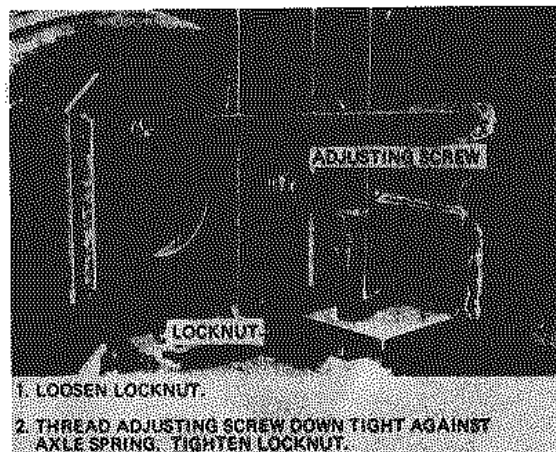

ME3895-342-12/2-1 C1

Figure 2-1. Axle spring adjusting screw.

- b. Disconnect hauling stub as instructed on figure 2-2.

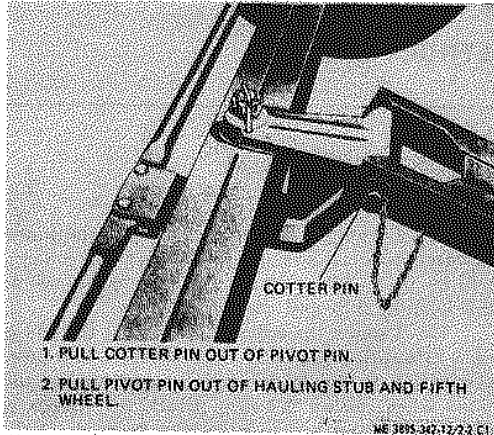

Figure 2-2. Disconnect hauling stub.

d. Disconnect water valve wrench retainer as instructed in figure 2-4.

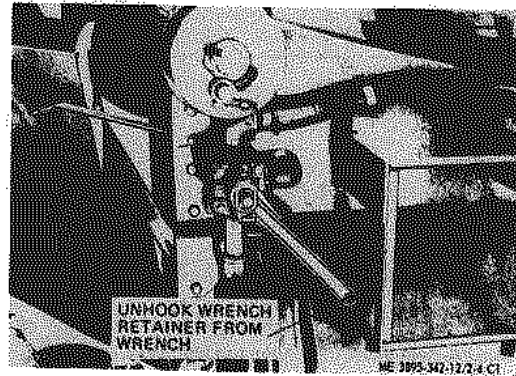

Figure 2-4. Water valve wrench retainer.

c. Disconnect skip hook as instructed on figure 2-3.

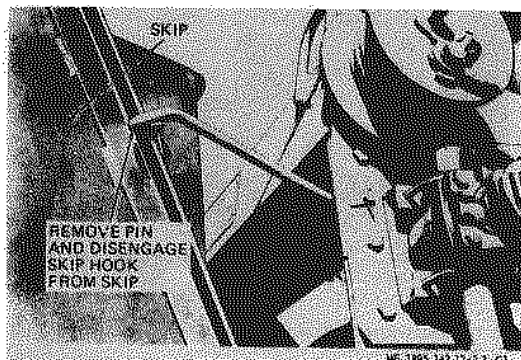

Figure 2-3. Skip hook.

e. Set the water gauge indicator lever for the amount of water to be discharged into the drum (fig. 2-5E).

f. Set up a barrel for the pump suction hose rather than dropping hose directly into a ditch or water hole. Provide an ample supply of water to mix the concrete required to clean and flush the concrete mixer after operation has ceased.

g. If the mixer is new, it will be necessary to prime the pump through the filler inlet (fig. 4-31). After initial priming, the pump should retain enough water to be self-priming.

Section II. MOVEMENT TO A NEW WORK SITE

2-3. Preparation for Movement

- Drain water from water tank.
- Connect retainer to end of water valve wrench in reverse of instructions on figure 2-4.
- Remove all concrete deposits from the exterior surface of mixing drum.
- Connect skip hook to skip in reverse of instruction, on figure 2-3.
- Loosen the adjusting screws at the end of each axle, spring in reverse of instructions on figure 2-1.
- Connect hauling stub to fifth wheel in reverse of instructions on figure 2-2.
- For short distance moves, tow mixer at speed not to exceed 20 MPH. Load mixer on flat bed truck or railway car for medium or long-distance moves.

2-4. Setting Up at New Work Site

Follow instructions given in paragraph 2-2.

Section III. CONTROLS AND INSTRUMENTS

2-5. General

This section illustrates the various controls and instruments and provides the operator/crew sufficient information to insure proper operation of the mixer.

2-6. Controls and Instruments

The purpose of the controls and instruments, and the normal maximum readings of the instruments are illustrated in figure 2-5.

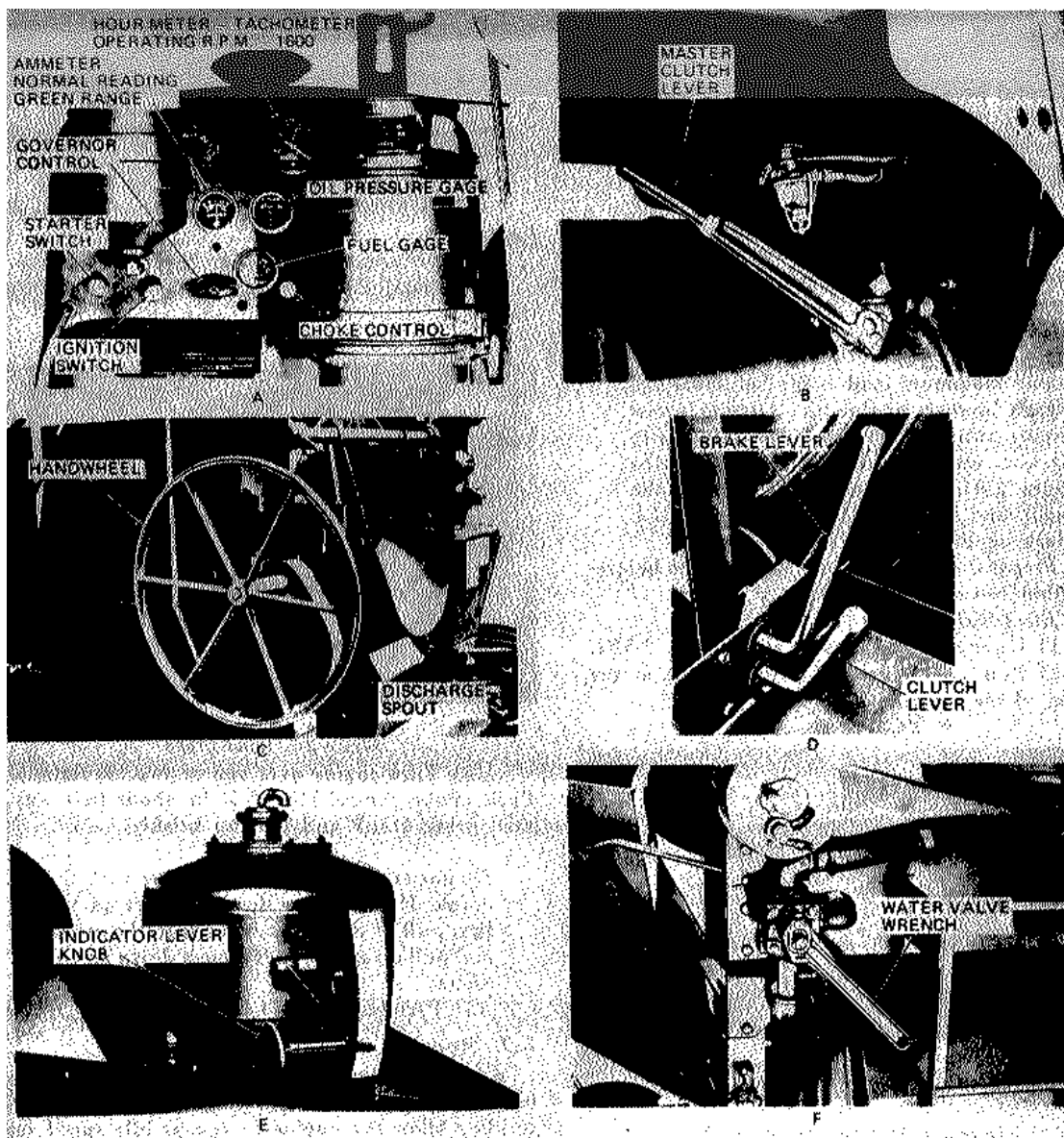

ME3895-342-12/5-1 C1

- A. Engine gauges, meters and controls
- B. Master clutch
- C. Discharge spout hand wheel

- D. Skip control
- E. Water gauge
- F. Water valve wrench

Figure 2-5. Controls and instruments.

Section IV. OPERATION UNDER USUAL CONDITIONS

2-7. General

a. The instructions in this section are published for the information and guidance of the personnel responsible for operation of the mixer.

b. The operator must know how to perform every operation of which the mixer is capable.

2-8. Starting

CAUTION

Careful breaking in of a new engine will greatly increase its life and result in trouble-free operation. Before engaging or putting a new engine to work, the new engine should be operated at low speeds (1000 to 1200 RPM's) for one-half hour, without load. The RPM should then be increased to engine operating speed, still without load, for an additional two hours. If at all possible, operate the engine at light loads for a period totaling eight hours, before maximum load is applied. This will greatly increase engine life. Starting a new engine, run it at idle for a few minutes to circulate and warm the oil, then stop engine (para 2-9). Recheck the oil level in the crankcase. Bring oil level up to the FULL mark on the oil gauge saber.

a. *Preparation for Starting.* Perform the before operation services (para. 3-4).

b. *Electrical Starting*

- (1) Disengage the master clutch (fig. 2-5B).
- (2) Pull out the ground switch button at the bottom of the magneto (fig. 2-6).

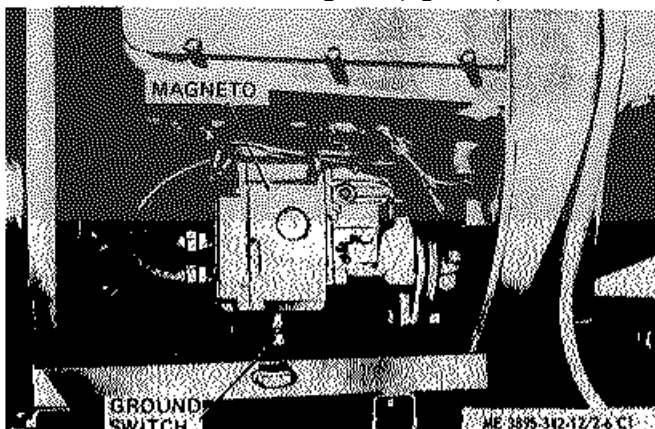

Figure 2-6. Magneto ground switch.

- (3) Pull out the ignition switch (fig. 2-5A).
- (4) Pull out choke control (fig. 2-5A) when starting a cold engine.

- (5) Be sure governor control (fig. 2-5A) is pushed in all the way.

(6) Press starter switch button (fig. 2-5A). When the engine starts, release the starter switch button. Do not operate the starter for more than 15 seconds at a time. If engine fails to start, allow the starter motor to cool for three minutes before another start attempt is made.

(7) After engine starts, push in choke control as required for smooth running. Allow the engine to run at idle for a few minutes to circulate and warm the oil.

c. *Manual Starting*

(1) Perform the before-operation services (para. 3-4).

(2) Perform steps (1) through (5) in above.

(3) Install the hand crank onto the crankshaft (fig. 2-7).

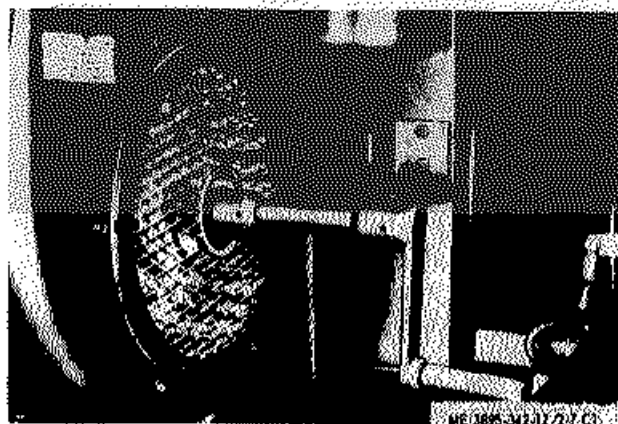

Figure 2-7. Hand Crank.

(4) Turn engine over one or two revolution.. Push choke control (fig. 2-5) in about half way. then grasp crank and pull up briskly.

CAUTION

Do not attempt to spin the engine with the crank. If the engine does not start on the first pull of the crank. re-engage the crank and pull up again. Never push down on the crank.

- (5) Perform step (7) in *b* above.

2-9. Stopping

a. *Preparation for Stopping.* Push the governor control (fig. 2-5A) in to decrease the engine speed to idle. Allow the engine to run at idle speed for several minutes to allow for even cooling.

b. *Stopping.*

- (1) Push in the ignition switch (fig. 2-5A) to stop the engine.

- (2) Perform the after-operation services (para. 3-4).

2-10. Operating the Mixer

CAUTION

When operating with DRY MIX, disengage water pump drive belt to prevent overheating and seizure of water pump A bearings.

- a. *Start the engine (para 2-8).*
- b. After engine warm-up, pull out the governor control (fig. 2-5A) until engine is running at operating speed (1600 RPM), then lock the governor control in position.
- c. Engage the master clutch (fig. 2-5B) to revolve drum.
- d. Load the skip with the stone or gravel first, then the sand, and then the cement. On very windy days, load the stone first, then the cement, and the sand last to hold down the cement dust.
- e. Engage the skip clutch (fig. 2-5D) easily but firmly.

CAUTION

Be sure to let go of the clutch lever once the clutch is engaged. When the top position of the skip is reached, the clutch disengages automatically, as the skip touches the knock-out lever. The skip brake grabs automatically as the clutch is disengaged and holds the skip in position until the brake is released.

f. Immediately after engaging the skip clutch, move the water valve wrench (fig. 2-5F) to the "Discharge-to-Drum" position. This lets some of the water into the drum before the materials slide out of the skip. This should permit some of the water to be flowing into the drum after the materials are all in. The timing of the water flow is very important and it is absolutely necessary to have some of the water going in ahead of the materials. It is also necessary to have the water going into the drum up to one side of the opening ahead of the materials. Never allow the water line to discharge directly into the middle of the drum. After the water flow into the drum has stopped, move the water valve wrench to the "Fill Tank" position.

g. Lower the skip by releasing the skip brake (fig. 2-SD). Engage the skip brake again just before the skip touches the ground. Let the skip down the rest of the way gently to prevent fouling of the cable on the winding drums.

h. Mixing-It generally takes about 60 seconds per batch for a thorough mix, and less time will result in a poor grade of concrete. If a very low slump or dry concrete is being mixed, it may require a few seconds longer per batch.

i. Discharge the batch from the drum by revolving the hand wheel control (fig. 2-5) clockwise. Be sure to reverse the discharge sprout before starting the skip up for charging the next batch.

j. When the pour has been finished, stop the engine (para 2-9).

k. When a pour has been finished, wash out the drum immediately because concrete tends to dry on the inside and stick to the steel. Use a hose or brush on the outside of the mixer every time the inside is cleaned. If the job is such that the mixer is in operation only now and then and is allowed to stand idle between batches, the drum should be washed out after the last batch unless the next pour is going to be started within an hour. This is especially true when heated materials are being used.

Section V. OPERATION UNDER UNUSUAL CONDITIONS

2-11. Operation in Extreme Cold

a. *Lubrication.* Lubricate in accordance with current lubrication order. Allow a longer time for warming up the engine to insure adequate lubrication reaching vital working parts.

b. *Fuel System.* Keep fuel tank full when not in operation.

c. *Electrical System.* Move wiring as little as possible to avoid damaging wire insulation. Keep batteries fully charged. After adding water to the batteries, run the engine for at least one hour.

d. *Water System.* Drain the water tank and pump after the last pour (of the day to prevent damage from freezing).

2-12. Operation in Extreme Heat

a. *Lubrication.* Lubricate in accordance with current lubrication order. Check the engine crankcase oil level frequently and keep level to FULL mark on oil gauge saber.

b. *Electrical System.* Check the batteries frequently for loss of water due to evaporation.

c. *Fuel System.* Fill the fuel tank at the end of each day's operation to prevent accumulation of vapor overnight. Make sure the oil in the air cleaner is at a proper level and is clean.

2-13. Operation in Dusty or Sandy Areas

a. *Lubrication.* Clean lubrication fittings before using grease gun. Clean fittings after lubrication.

Lubricate sparingly but more often. Clean oil filler cap and opening before servicing. Service air cleaner and oil filter frequently.

b. Fuel System. Keep fuel tank clean and tightly covered. Service the fuel strainer daily.

2-14. Operation Under Humid Conditions Or In Salt Water Areas

a. General. Salt water causes rapid corrosion. Keep equipment clean. Wash the mixer frequently with clean, fresh water to prevent salt water corrosion. When possible, use natural barriers erected to protect the mixer.

b. Fuel System. Fill fuel tank at end of day's operation to minimize condensation. Service the fuel strainer daily.

c. Electrical System. Salt water and high humidity cause corrosion and poor connections in electrical components. Remove corrosion from the connections when evident. Coat the battery terminals with grease to protect them from the weather.

d. After operational cleaning, apply lubricant to exposed finished surfaces and cables to prevent rust and/or corrosion damage.

2-15. Operation at High Altitudes.

As altitude increases, the density of air decreases with a resultant decrease in oxygen for combustion and a reduction in horsepower. For each 1, 000 feet of altitude above sea level there will be 3½ reduction in horsepower.

CHAPTER 3

OPERATOR/CREW MAINTENANCE INSTRUCTIONS**3-1. Tools, Equipment and Repair Parts**

Tools, equipment and repair parts issued with or authorized for the mixer are listed in the Basic Issue Items list, appendix C of this manual.

Section II. LUBRICATION INSTRUCTIONS**3-2. General**

For the current lubrication order, refer to DA PAM 310-4.

3-3. Detailed Lubrication Information

a. General. Keep all lubricants in closed containers and stored in a clean, dry place away from external heat. Allow no dust, dirt, or other foreign materials to mix with the lubricants. Keep all lubrication equipment clean and ready to use.

b. Cleaning. Keep all external parts not requiring lubrication clean of lubricants. Before lubricating the equipment wipe all lubrication points free of dirt and grease. Clean all lubrication points after lubricating to prevent accumulation of foreign matters.

c. Points of Lubrication.

(1) Service the lubrication points at proper intervals as instructed in the current lubrication order.

(2) Apply pressure lubricant until clean lubricant comes from the part being lubricated.

d. Special Lubrication Instructions. The service intervals are based on hours of normal operation. Shorten intervals to compensate for abnormal operations and severe conditions. During inactive periods, intervals may be lengthened to the point where lubrication protection is assured.

Section III. PREVENTIVE MAINTENANCE CHECKS AND SERVICES**3-4. Maintenance Forms and Records**

Every mission begins and ends with the paperwork. There isn't much of it, but you have to keep it up. The forms and records you fill out have several uses. They are a permanent record of the services, repairs, and modifications made on your equipment; they are reports to organizational maintenance and to your commander; and they are a checklist for you when you want to know what is wrong with the equipment after its last use, and whether those faults have been fixed. For the information you need on forms and records, see TM 38750.

3-4-1. Preventive Maintenance Checks and Services

a. Do your (B) PREVENTIVE MAINTENANCE just before you operate the equipment. Pay attention to the CAUTIONS and WARNINGS.

b. Do your (D) PREVENTIVE MAINTENANCE during operation. (During operation means to monitor the mixer and its related components/ systems while they are actually being operated.)

c. Do your (A) PREVENTIVE MAINTENANCE right after operating the equipment. Pay attention to the CAUTIONS and WARNINGS.

d. Do your (W) PREVENTIVE MAINTENANCE weekly.

e. Do your (M) PREVENTIVE MAINTENANCE once a month.

f. If something doesn't work, troubleshoot it with the instructions in this manual or notify your supervisor.

g. Always do your preventive maintenance in the same order, so it gets to be a habit. Once you've had some practice, you'll spot anything wrong in a hurry.

h. If anything looks wrong and you can't fix it, write it on your DA Form 2404. If you find something seriously wrong, report it to organizational maintenance RIGHT NOW.

i. When you do your preventive maintenance, take along the tools you need to make all the checks. You always need a rag or two.

WARNING

Dry cleaning solvent, SD-2 used to clean parts, is potentially dangerous to personnel and property. Do not use near open flame or excessive heat. Flash point of solvent is 138° F.

(1) *Keep it clean.* Dirt, grease, oil, and debris only get in the way and may cover up a serious problem. Clean as you work and as needed. Use dry-cleaning solvent (SD-2) to clean metal surfaces. Use soap and water when you clean rubber or plastic material.

(2) *Bolts, nuts, and screws.* Check them all for obvious looseness, missing, bent, or broken condition. You can't try them all with a tool, of course, but look for chipped paint, bare metal, or rust around bolt heads. If you find one you think is loose, tighten it, or report it to organizational maintenance, if you can't tighten it.

(3) *Welds.* Look for loose or chipped paint, rust, or gaps where parts are welded together. If you find a bad weld, report it to organizational maintenance.

(4) *Electric wires and connectors.* Look for cracked or broken insulation, bare wires, and loose or broken connectors. Tighten loose connectors and make sure the wires are in good condition.

(5) *Hoses and fluid lines.* Look for wear, damage, and leaks. Make sure clamps and fittings are tight. Wet spots show leaks, of course, but a stain around a fitting or connector can also mean a leak. If a leak comes from a loose fitting or connector, tighten it. If something is broken or worn out, report it to organizational maintenance.

j. It is necessary for you to know how fluid leakage affects the status of your equipment. The following are definitions of the types/classes of leakage you need to know to be able to determine the status of your equipment. Learn and be familiar with them and REMEMBER When in doubt, notify your supervisor!

Leakage definitions for Operator/Crew PMCS

CLASS I Seepage of fluid (as indicated by wetness or discoloration) not great enough to form drops.

CLASS II Leakage of fluid great enough to form drops but not enough to cause drops to drip from item being checked/ inspected.

CLASS I Leakage of fluid great enough to form drops that fall from the item being checked/inspected.

CAUTION

Equipment operation is allowable with minor leakage (Class I or II). Of course, consideration must be given to the fluid capacity in the item/system being checked/inspected. When in doubt, notify your supervisor.

When operating with Class I or II leaks, continue to check fluid levels as required in your PMCS.

Class III leaks should be reported to your supervisor or to organizational maintenance.

Table 3-1. Operator/Crew Preventive Maintenance Checks and Services

Item No.	Interval					ITEM TO BE INSPECTED Procedure: Check for and have repaired, filled, or adjusted as needed	Equipment is not ready/ available if:
	B	D	A	W	M		
1	•					<p>NOTE PERFORM WEEKLY AS WELL AS BEFORE PMCS IF:</p> <p>a. You are the assigned operator but have not operated the equipment since the last weekly.</p> <p>b. You are operating the equipment for the first time.</p> <p>GENERAL</p> <p>a. Visually check for loose wiring, damaged piping or hoses</p> <p>b. Check for evidence of fluid leaks (oil, fuel, water).</p>	Class III leaks evident. No fuel leakage allowed.
2	•					<p>ENGINE CRANKCASE Check dipstick for proper oil level. Add oil as necessary to FULL mark.</p>	
3	•					<p>FUEL STRAINER Inspect sediment bowl for dirt or water. Clean if contaminated.</p>	Broken or cracked sediment bowl.

Table 3-1. Operator/Crew Preventive Maintenance Checks and Services-Continued

Item No.	Interval					ITEM TO BE INSPECTED Procedure: Check for and have repaired, filled, or adjusted as needed	Equipment is not ready/available if:
	B	D	A	W	M		
4		•				CONTROLS (Check for proper operation) a. Governor (1600 RPM) and choke control. b. Handwheel c. Water valve. d. Clutch and brake lever.	Governor does not control. Broken or will not operate. Broken or will not operate. Broken or will not operate.
5		•				INSTRUMENTS (Check for proper indication) a. Engine oil pressure gauge-Green range normal operation. b. Ammeter-Green range normal operation. c. Hour Meter/Tachometer-1600 RPM normal operation. d. Water gauge.	Engine oil pressure gauge or ammeter indicates abnormal operation.
6			•			DRUM Use a hose and brush and clean mixer thoroughly, both inside and outside of drum.	
7				•		BELTS Inspect generator, hoist, and pump drive belts for frayed or cracked condition.	Belt missing or broken.
8		•				HOIST CABLE Inspect cable for broken, kinked, or flattened strands. Check for obvious wear, corrosion or abrasions.	Cable is broken, obviously worn or corroded
9				•		AIR CLEANER Inspect the air cleaner bowl for dirt and improper oil level. Clean the bowl if dirty and fill with oil to indicated level.	
10				•		BATTERIES Check level of electrolyte. If low, fill with clean water (distilled if possible) to the split ring. In freezing weather, run engine at least 15 minutes after adding water.	
11					•	TIRES a. Check for cuts and general condition. b. Check for correct air pressure (50 PSI).	

Section IV. TROUBLESHOOTING

3-5. General

This section provides information useful in diagnosing and correcting unsatisfactory operation or failure of the mixer and its components. Malfunctions which may occur are listed in table 3-2. A list of probable causes is described opposite each malfunction. The corrective action recommended is described opposite the probable cause.

Section V. OPERATOR'S MAINTENANCE

3-6. General

The instructions in this section are published for the information and guidance of the operator to maintain the mixer.

3-7. Fuel Tank Service

Service the fuel tank as instructed on figure 3-1.

REMOVE STRAINER FROM TANK. CLEAN SCREEN THOROUGHLY AND INSPECT FOR DAMAGE

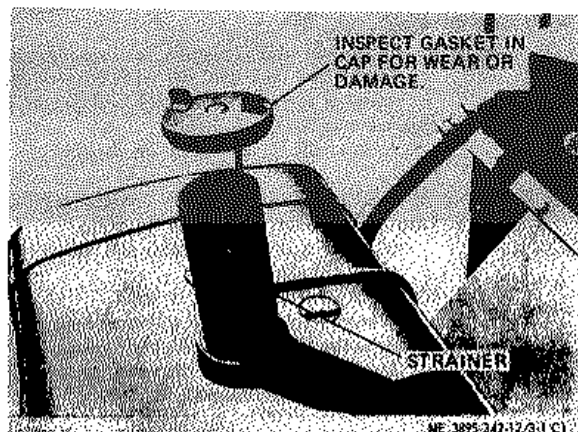

Figure 3-1. Fuel tank service.

Table 3-2. Troubleshooting

MALFUNCTION	TEST OR INSPECTION	CORRECTIVE ACTION
1. STARTING MOTOR WILL NOT CRANK ENGINE.	Step 1. Inspect battery cables for loose or corroded condition.	If cables are loose or corroded, clean and tighten cables.
2. ENGINE FAILS TO START, OR IS HARD TO START.	Step 1. Check for empty fuel tank.	Refill fuel tank if empty or low.
	Step 2. Check to see if shutoff valve is closed.	Open fuel shutoff valve (fig. 3-2).
	Step 3. Inspect fuel strainer to see if it is dirty.	If dirty clean fuel strainer.
	Step 4. Check to see if carburetor is flooded.	If flooded, crank engine with choke open.
	Step 5. Check to see if carburetor is choked sufficiently.	If not, crank with choke closed.
3. HIGH OIL CONSUMPTION	Step 1. Check to see if oil level is too high in crankcase.	See current lubrication order for correct oil level in crankcase.
	Step 2. Check to see if wrong grade of oil is need in crankcase.	Refer to current lubrication order for proper grade of oil.

MALFUNCTION**TEST OR INSPECTION****CORRECTIVE ACTION****4. ENGINE STOPS**

- Step 1. Inspect tank to see if it is empty.
Refill empty or low fuel tank.

5. ENGINE OVERHEATS

- Step 1. Check to see if low grade of gasoline is used.
Drain fuel tank and fill with correct grade of gasoline. Use gasoline that conforms to Military Specifications MILG-3056 or MIL-F-5572.
- Step 2. Inspect to see if cooling air circulation is restricted.
Move mixer to provide proper air circulation.
- Step 3. Check to see if engine is overloaded.
If overloaded, reduce amount of batch.
- Step 4. Check to see if engine crankcase oil level is low.
Fill to full mark on dipstick.

6. ENGINE KNOCKS.

- Step 1. Check to determine if gasoline is of a poor grade or low octane rating.
Drain fuel tank and fill with correct grade of gasoline. Use gasoline that conforms to military specifications MIL-G-3056 or MIL-F-5572.
- Step 2. Inspect crankcase oil level.
If low, fill to full mark on dipstick.

7. ENGINE BACKFIRES THROUGH CARBURETOR

- Step 1. Inspect for water or dirt in gasoline.
If water and dirt is discovered, drain contaminated gasoline from fuel tank and fill with clean gasoline.
- Step 2. Check engine to see if it is cold.
If cold, allow engine to warm up before applying load.
- Step 3. Check to see if gasoline is of a poor grade.
Drain fuel tank and fill with correct grade of gasoline. Use gasoline that conforms to Military Specifications MIL-G-3056 or MIL-F-5572.

8. WATER PUMP FAILS TO TAKE PRIME

- Step 1. Check to see if there are loose hose connections.
If loose, tighten all hose clamps and pipe fittings.
- Step 2. Inspect end of suction line to see if it is clogged.
If clogged. clear suction line.

9. WATER PUMP FAILS TO PUMP.

- Step 1. Inspect pump to see if it is properly primed.
If not prime pump.

10. INSUFFICIENT WATER THROUGH PUMP

- Step 1. Check for air leak in suction line.
If air leak is present tighten suction line.
- Step 2. Check to see if suction lift is too high or total lift is more than that for which pump is intended.
Move mixer closer to source of water

3-8. Fuel Strainer Service

Service the fuel strainer as instructed on figure 3-2.

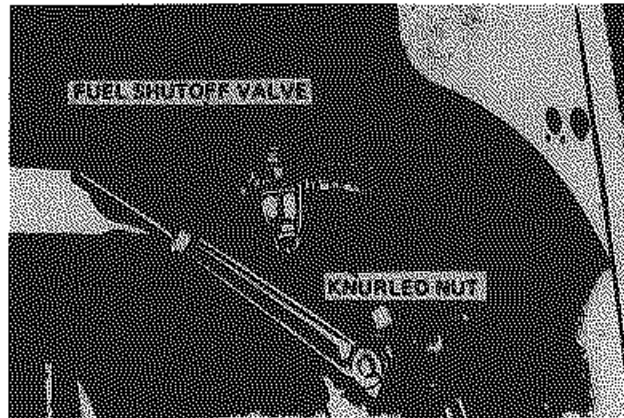

ME3895-342-12/3-3 C1

Figure 3-2. Fuel strainer service.

1. CLOSE FUEL SHUTOFF VALVE.
2. LOOSEN KNURLED NUT AND SWING WIRE BAIL TO ONE SIDE.
3. CLEAN BOWL AND SCREEN THOROUGHLY. REPLACE DEFECTIVE GASKET.

3-9. Oil Filler Breather Service

Service the oil filler breather as instructed on figure :3-3.

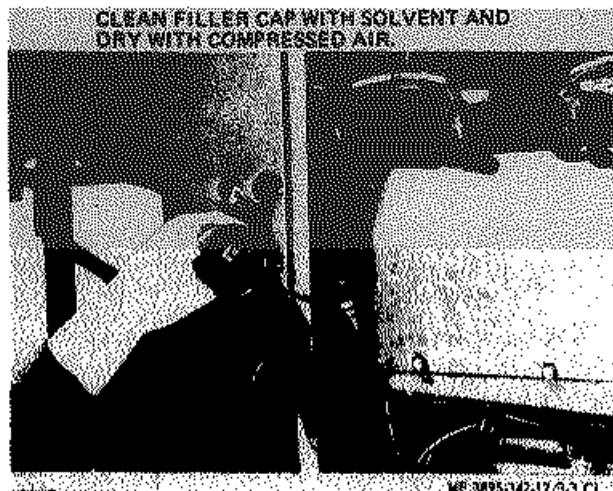

Figure 3-3. Oil filter breather service.

3-10. Battery Service

Service the batteries as instructed on figure 3-4.

WIPE BATTERIES, CABLES AND FILLER CAPS CLEAN. REMOVE FILLER CAPS AND CLEAN VENT HOLES. ELECTROLYTE LEVEL MUST BE 3/8 INCH ABOVE PLATES.

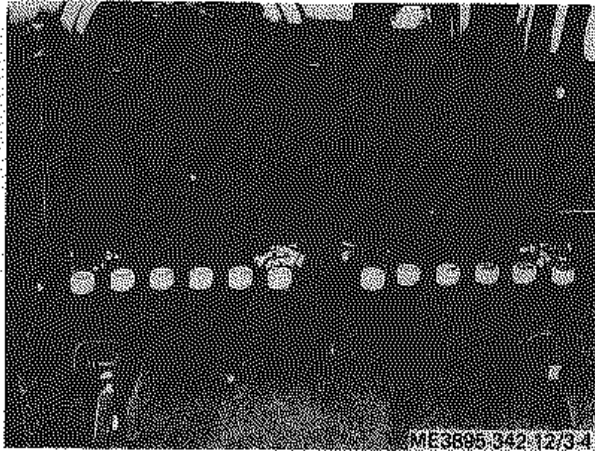

Figure 3-4. Battery service.

3-11. Tire Service

Check pressure in each tire with a reliable tire gage. Fill tires to 50 P.S.I.

CHAPTER 4

ORGANIZATIONAL MAINTENANCE INSTRUCTIONS

SECTION I. SERVICE UPON RECEIPT OF MATERIAL

4-1. Inspecting and Servicing the Equipment

a. Perform the following inspection and services upon receipt of equipment.

(1) Check all parts against the packing list for loss or theft.

(2) Inspect engine thoroughly for evidence of damaged or disconnected lines and wires.

(3) Inspect engine hold-down bolts for tightness.

(4) Remove drain plugs from tool box on mixer and install in drum (fig. 4-1), water tank (fig. 4-21). And water pump (fig. 4-3).

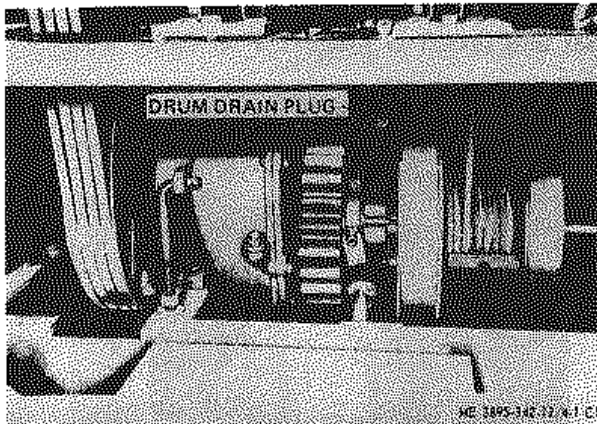

Figure 4-1. Drum drain plug.

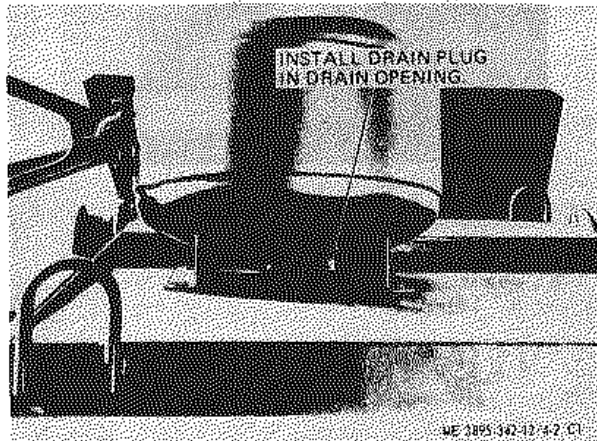

Figure 4-2. Water tank drain plug.

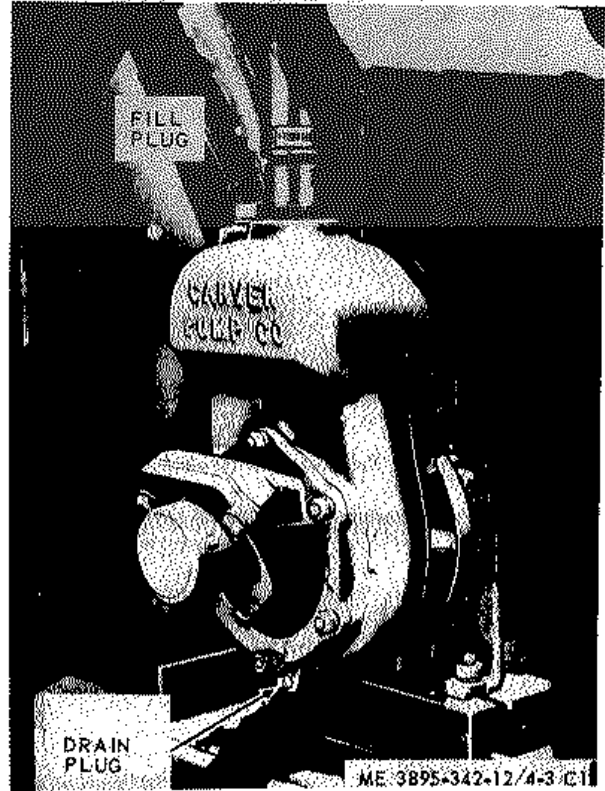

Figure 4-3. Water pump drain plug.

(5) Inspect engine crankcase drain plug (fig. 4-4) for tightness.

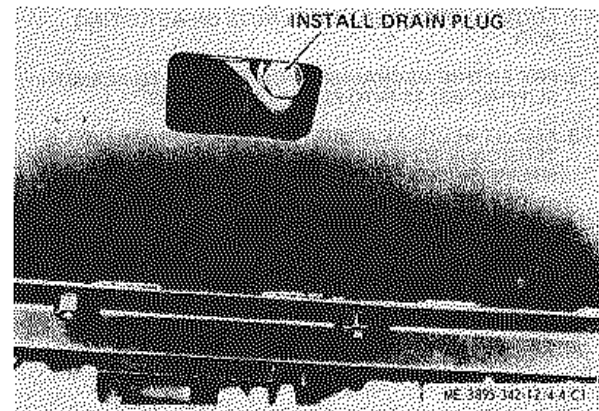

Figure 4-4. Engine crankcase drain plug.

(6) Remove belt guard (fig. 4-5). Install hoist drive belts (packed in tool box) as instructed on figure 4-6. Install pump drive belt packed in tool box) as instructed on figure 4-7.

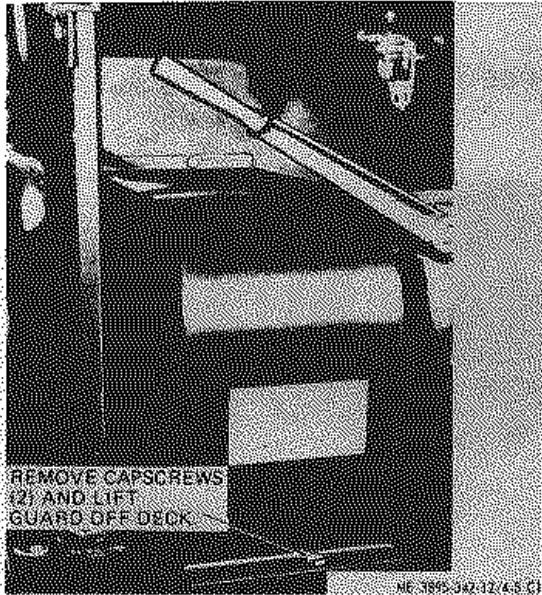
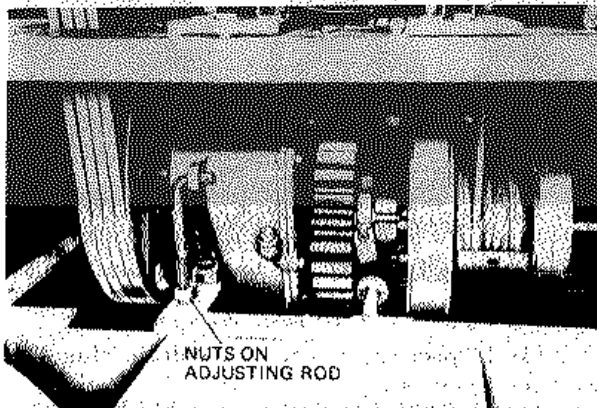

Figure 4-5. Belt guard removal.



1. LOOSEN UPPER AND LOWER NUTS ON ADJUSTING ROD.
2. PRY ENTIRE MECHANISM HIGH ENOUGH TO PERMIT SLIPPING BELTS INTO PLACE ON SHEAVES.
3. ADJUST BELTS AT ADJUSTING ROD. CORRECT BELT TENSION IS 1/2 INCH DEFLECTION MIDWAY BETWEEN SHEAVES.

ME 3895-342-12/4-6 C1

Figure 4-6. Hoist drive belts installation and adjustment.

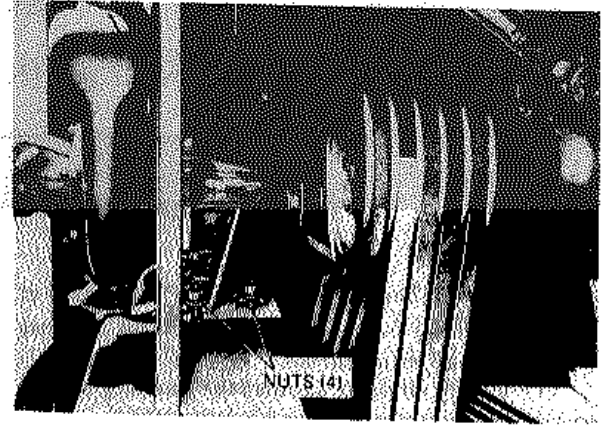

1. LOOSEN NUTS (4) AND MOVE PUMP JUST FAR ENOUGH TO PERMIT SLIPPING BELT INTO PLACE ON SHEAVES.
2. MOVE PUMP TO ADJUST BELT TENSION THEN TIGHTEN NUTS (4). CORRECT BELT TENSION IS 1/2 INCH DEFLECTION MIDWAY BETWEEN SHEAVES.

ME 3895-342-12/4-7 C1

Figure 4-7. Pump drive belt installation and adjustment.

(7) Remove fire extinguisher from tool box on mixer and install as instructed on figure 4-8.

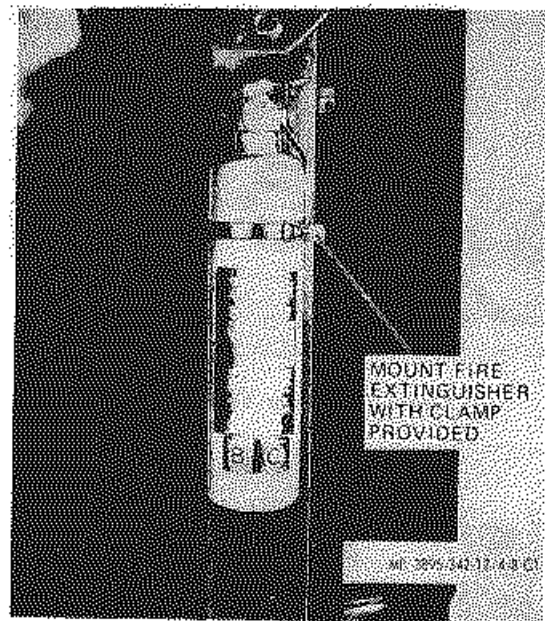

Figure 4-8. Fire extinguisher installation.

(8) Open battery box, remove the battery caps and pour sufficient electrolyte into each cell to cover the plates to a depth of 5/8 inch. Re-install battery caps.

WARNING

Use care in handling the electrolyte as

severe burns will result if acid is spilled on skin.

b. Perform lubrication service as instructed in paragraph 3-2.

c. Perform daily preventive maintenance checks and services as instructed in paragraph 4-5.

SECTION II. REPAIR PARTS, SPECIAL TOOLS, AND EQUIPMENT

4-2. Tools and Equipment.

Tools, equipment and repair parts issued with or authorized for the mixer are listed in the Basic Issue Items List, Appendix C of this manual.

4-3. Special Tools and Equipment

No special tools or equipment are required by organizational personnel for maintenance of the mixer.

4-4. Maintenance Repair Parts

Repair parts and equipment will be listed and illustrated in the repair parts and special tools list covering organizational maintenance for this equipment in TM 5-3895-342-20P.

SECTION III. PREVENTIVE MAINTENANCE CHECKS AND SERVICES

4-5. General

Preventive maintenance is detecting/correcting problems before they happen, or fixing little problems before they become big problems. Table 4-1 contains a list of preventive maintenance checks and services to be performed by organizational maintenance personnel. Attention to these checks and services will increase the useful life of the equipment, but every possible problem cannot be covered in the PMCS. You need to be alert for anything that might cause a problem. If anything does look wrong, and you can't fix it, write it on a DA Form 2404 and report it to your supervisor. Be sure to record any corrective action.

WARNING

Dry cleaning solvent, SD-2, used to clean parts is potentially dangerous to personnel and property. Do not use near open flame or excessive heat. Flash point of solvent is 138°F.

c. Make cleanup a part of your preventive maintenance. Dirt, grease, oil, and debris may cover up a serious problem. Use drycleaning solvent (SD-2) to clean metal surfaces. Wipe off excess grease and spilled oil. Use soap and water when you clean rubber or plastic material.

d. Watch for and correct anything that might cause a problem with the equipment. Some things you should watch for are:

- (1) Bolts, nuts, and screws that are loose, missing, bent, or broken.
- (2) Welds that are bad or broken.
- (3) Electric wires and connectors that are bare, broken, or loose.
- (4) Hoses and fluid lines that leak, or show signs of damage or wear.

e. You should know how fluid leaks affect the status of your equipment. Learn and be familiar with the following types/classes of leakage. When in doubt, notify your supervisor!

Leakage definitions for PMCS are:

CLASS I Seepage of fluid (as indicated by wetness or discoloration) not great enough to form drops.

CLASS II Leakage of fluid great enough to form drops but not enough to cause drops to drip from the item being

4-5-1. Organizational Preventive Maintenance Checks and Services

a. Perform the checks and services at the intervals shown in table 4-1.

(1) Do the (Q) PREVENTIVE MAINTENANCE checks and services once each three months.

(2) Do the (S) PREVENTIVE MAINTENANCE twice a year, or each six months.

(3) Do the (A) PREVENTIVE MAINTENANCE once each year.

(4) Do the (B) PREVENTIVE MAINTENANCE once each two years.

(5) Do the (H) PREVENTIVE MAINTENANCE at the hour interval listed.

b. If the mixer doesn't work properly and you can't see what is wrong, refer to Section IV for troubleshooting instructions.

checked/inspected.
 CLASS III Leakage of fluid great enough to form drops that fall from the item being checked/inspected.

capacity in the item/system being checked/inspected. When in doubt, notify your supervisor.
 When operating with Class I or II leaks, continue to check fluid levels as required in your PMCS.
 Class III leaks should be corrected before releasing equipment for operation.

CAUTION

Equipment operation is allowable with minor leakage (Class I or II). Of course, consideration must be given to the fluid

Table 4-1. Organizational Preventive Maintenance Checks and Services

Item No	Interval						ITEM TO BE INSPECTED Procedure
	Q	S	A	B	H	MI	
							<p>NOTE PERFORM OPERATOR/CREW PMCS PRIOR TO OR IN CONJUNCTION WITH ORGANIZATIONAL PMCS.</p>
1	•						<p>ENGINE a. Check for loose or missing mounting hardware. b. Check electrical wiring for damage or loose connections.</p>
2	•		•				<p>FLYWHEEL AND AIR SHROUDS Check the vanes on the flywheel for cracks or breaks. Check the air shroud for loose mountings, bends, or cracks.</p>
3		•					<p>VALVE TAPPETS Inspect valve tappets for proper adjustment. With engine cold the clearance should be, inlet 0.008 inch and exhaust 0.016 inch.</p>
4		•					<p>MAGNETO Remove the end cover and inspect for cracks and corroded terminals. Examine the breaker points for burning and pitting. Check breaker point gap, 0.015 inch.</p>
5		•					<p>SPARK PLUGS AND LEADS Inspect spark plugs for dirty or broken insulators. Check spark plug electrode condition and gap, 0.030. Inspect leads for worn or frayed condition.</p>
6		•					<p>BATTERIES Inspect cables for fraying and corrosion. Clean corrosion from the battery and tighten loose cable clamps. Check specific gravity of electrolyte in each cell.</p>
7		•					<p>MASTER CLUTCH Check the adjustment. The clutch should engage and disengage freely, hold securely when engaged, and not drag when disengaged.</p>
8	•	•					<p>TOWING SAFETY CHAIN Inspect the safety chain for wear, broken links, and corrosion. Replace worn or broken chain links.</p>
9	•						<p>BELTS Inspect generator, hoist, and pump drive belts for damage and wear. Replace or adjust as necessary. Proper belt adjustment will permit a 1/2 inch deflection midway between pulleys.</p>

SECTION IV. TROUBLESHOOTING

4-6. General

This section provides information useful to diagnosing and correcting unsatisfactory operation or failure of the mixer and its components.

Malfunctions which may occur are listed in table 4-2. A test or inspection procedure is listed under each malfunction. The corrective action recommended is described under the probable cause

Table 4-2. Troubleshooting

MALFUNCTION	TEST OR INSPECTION	CORRECTIVE ACTION
1. STARTING MOTOR WILL NOT START MOTOR	Step 1. Check to see if batteries are discharged or defective. If discharged or defective replace batteries (para 4-21).	
	Step 2. Inspect ignition switch and ignition switch wiring to see if either is defective. If defective, replace ignition switch and wiring (para 4-40).	
	Step 3. Inspect to see if start switch or wiring is defective. If start switch is defective replace (para 4-41).	
	Step 4. Inspect for defective starting motor. If defective replace starting motor (para 4-23).	
2. ENGINE FAILS TO START	Step 1. Check to see if engine is out of time. If out of time, adjust timing (para 4-24).	
	Step 2. Check to see if spark plug point gap is wrong. Remove spark plugs (para 4-25) and adjust gap to .030 inch.	
	Step 3. Check magneto contact points to see if they are defective or out of adjustment. Adjust contact points or replace points if defective (para 4-24).	
	Step 4. Inspect magneto condenser to see if it is shorted. Test magneto condenser and replace if defective (para 4-24).	
	Step 5. Inspect for poor compression. Adjust valve tappets (para 4-14).	
3. ENGINE STOPS	Step 1. Inspect magneto condenser to see if it is shorted. Test magneto condenser and replace if defective (para 4-24).	
4. ENGINE OVERHEATS	Step 1. Check to see if timing is incorrect. If timing is incorrect, time magneto to engine (para 4-24).	
	Step 2. Inspect to see that air flow through cylinder air shrouds are not obstructed. Clean air shrouds and inspect for excessive damaged. Replace damaged shroud components as necessary (para 4-19).	
	Step 3. Inspect for back pressure in exhaust line. If muffler is defective replace muffler (para 4-11).	
5. EXCESSIVE FUEL CONSUMPTION	Step 1. Inspect carburetor to see if it is out of adjustment. If carburetor is out of adjustment, adjust carburetor (para 4-30).	
	Step 2. Inspect carburetor to see if float sticks. If float sticks, replace carburetor (para 4-30).	
	Step 3. Check timing to see if it is incorrect. If timing is incorrect. time magneto to engine (para 4-24).	
6. LOW OIL PRESSURE	Step 1. Inspect oil pressure gage to see if it is defective. If defective, replace gage (para 4-43).	
7. PUMP FAILS TO OPERATE	Step 1. Check to see if pump speed is too low. If speed is too low. check for broken belt or belt out of adjustment. Replace or adjust pump bolt (para 4-49).	
8. PUMP HAS, INSUFFICIENT CAPACITY	Step 1. Check to see if speed is too low. If speed is too low. Check for belt out of adjustment (para 4-49).	

SECTION V. RADIO INTERFERENCE SUPPRESSION

4-7. General

Essentially, suppression is attained by providing a low resistance path to ground for the stray currents. The methods used include shielding the ignition and high-frequency wires, grounding the frame with bonding straps, and using capacitors and resistors.

4-8. Interference Suppression Component

a. Primary Suppression Components. The primary suppression components are those whose primary function is to suppress radio interference. They consist of internal-toothed lockwashers installed under the heads and under the nuts of attaching hardware and grounding straps from engine and instrument panel to the frame.

b. Secondary Suppression Components. These components have radio interference

suppression functions which are incidental or secondary to their primary function. The components are the magneto condenser (refer to para 4-24 for removal of magneto condenser) and spark plugs and leads (refer to para 4-25 for removal of spark plugs and leads).

4-9. Testing of Radio Interference Suppression Components

Test the magneto condenser for leaks and shorts on a suitable tester; replace a defective condenser. If test equipment is not available and interference is indicated, isolate the cause of interference by the trial-and-error method of replacing each suppression component in turn until the cause of interference is located and eliminated.

SECTION VI. ENGINE MUFFLER, HOUSING, FLYWHEEL, AND VALVE TAPPETS

4-10. General

The engine is enclosed in a sheet metal housing consisting of a top canopy, a rear housing panel, a flywheel housing, two side panels, and a front panel. The muffler is of the flat baffle type, extending above the top canopy.

4-11. Muffler

a. Removal. Unscrew the muffler from the muffler adapter nipple (fig. 4-9A).

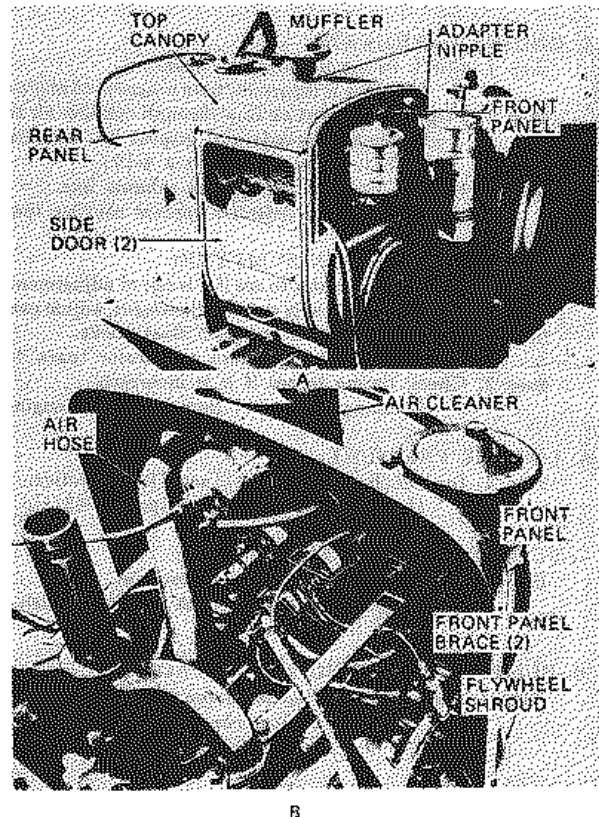

MS 3895-342-12-4-9 C1

Figure 4-9. Engine muffler, top canopy, side doors, and front panel removal.

b. Cleaning, Inspection and Repair.

(1) Clean the muffler and the muffler adapter nipple with a stiff wire brush.

(2) Inspect for stripped or damaged threads.

(3) Inspect the muffler for cracks, dents, or corrosion. Replace a damaged muffler.

c. Installation. Screw the muffler on to the muffler adapter nipple.

4-12. Engine, Top Canopy, Side Doors, and Front Panel

a. Removal.

(1) Remove the muffler (para 4-11).

(2) Remove the side doors (fig. 4-9) from the engine.

(3) Remove the screws and lockwashers securing the top canopy to the rear and front panels.

(4) Remove the bolts securing the braces to the front panel.

(5) Loosen the clamp securing the air hose to the air cleaner.

(6) Loosen the screws securing the choke control wire to the carburetor swivel lever (fig. 4-32).

(7) Remove the cotter pin securing the chain to the governor control (fig. 4-33).

CAUTION

Disconnect battery ground cable before working on electrical system.

(8) Disconnect leads to the ammeter, the ignition switch, starter switch, and fuel level gage (fig. 4-341).

(9) Disconnect the oil lines at the oil pressure gage (fig. 4-34) and at the oil filter housing (fig. 4-29).

(10) Remove the screws securing the front panel to the flywheel shroud and lift off the front panel (fig. 4-9).

b. Cleaning, Inspection and Repair.

(1) Clean all parts with a cleaning solvent.

(2) Inspect the top canopy, side doors, and front panel for cracks and dents. Replace excessively damaged parts.

(3) Inspect all hardware for damage. Replace as necessary.

c. Installation. Install the engine top canopy, side doors, and front panels in reverse of instructions in a above.

4-13. Flywheel and Flywheel Shroud

a. Removal.

(1) Remove the muffler (para 4-11).

(2) Remove the engine top canopy, side doors, and front panel (para 4-12).

(3) Remove the screws securing the flywheel screen to the flywheel shroud (fig. 4-10).

(4) Drive out the starting crank pin from the crankshaft.

(5) Remove the flywheel nut and washer and while pulling out on the flywheel, strike the end of the crankshaft with a babbitt hammer. The flywheel will slide off the taper of the crankshaft.

CAUTION

When re-assembling the flywheel, be sure that the Woodruff key is in position on the crankshaft and that the keyway in the flywheel is lined up accurately with the key.

(6) Remove the cap screws and lockwashers securing the flywheel shroud in the engine.

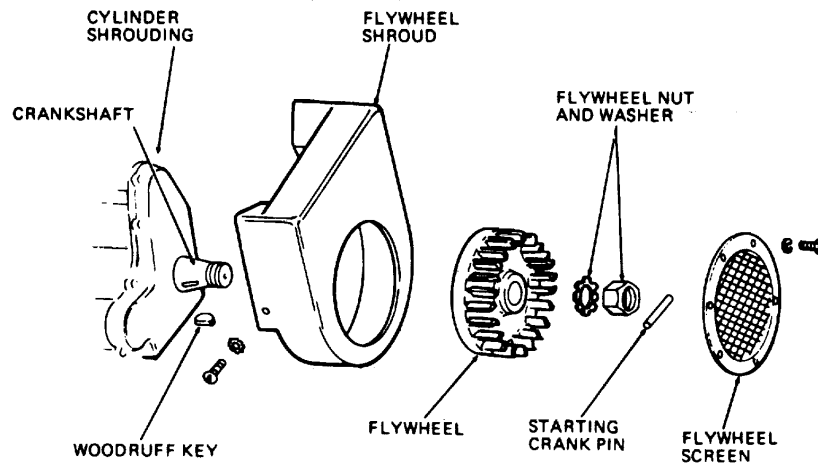

ME 3895-342-12/4-10 C1

Figure 4-10. Flywheel and flywheel shroud removal.

b. Cleaning and Inspection.

- (1) Clean all parts with a cleaning solvent.
- (2) Inspect all parts for wear or damage.
Replace worn or damaged parts.

c. Installation. Install the flywheel and flywheel shroud in reverse of instructions of a above.

4-14. Valve Tappets Adjustment

a. General. The tappets lift the valves in proper sequence with the wiring order of the engine (1, 3, 4, 2). The tappets are lifted by lobes on the camshaft. The tappets are adjustable and have a lock screw to retain adjustment.

b. Adjustment.

- (1) Remove the lower manifolds (para 4-17).
- (2) Remove the screws securing the flywheel screen to the flywheel shroud (fig. 4-10).
- (3) Remove the cylinder air shrouds (para 4-19).

(4) Remove the capscrew, washer, valve tappet cover, and gasket from the engine (fig. 4-11).

(5) Remove the spark plug from No. 1 cylinder (fig. 4-21).

(6) Adjust the valve tappets as shown in figure 4-12. With the tappets in their lowest positions, engine cold, the clearance should be 0.008 inch for the inlet and 0.016 inch for the exhaust.

(7) Install the spark plug in No. 1 cylinder (fig. 4-21).

(8) Install the gasket, valve tappet cover, washer, and attaching capscrew (fig. 4-11).

(9) Install the cylinder air shrouds (para 4-11).

(10) Install the flywheel screen (fig. 4-10).

(11) Install the lower manifold (para 4-17).

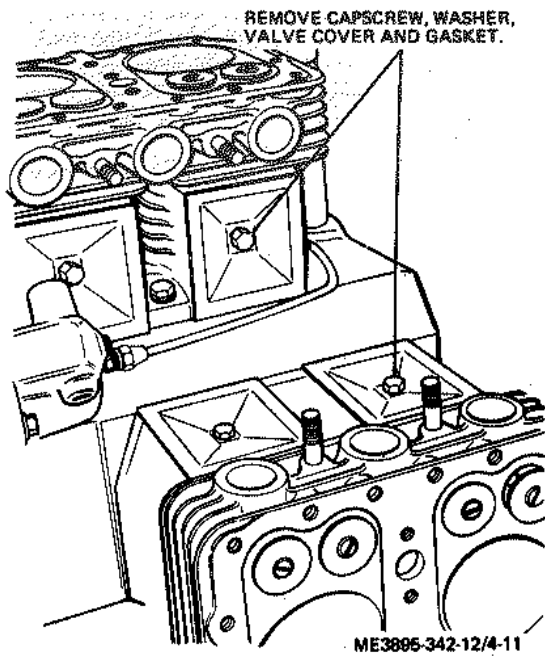

Figure 4-11. Valve tappet cover.



Figure 4-12. Valve tappet adjustment.

SECTION VII. UPPER AND LOWER MANIFOLDS

4-15. General

The manifolds are cast in three separate pieces, each piece functioning as an exhaust and inlet manifold. The two lower manifolds attach to the cylinder block while the upper manifold attaches to the lower manifolds.

4-16. Upper Manifold

a. Removal.

- (1) Remove the muffler (para 4-11).
- (2) Remove the top canopy, side doors and front panel (para 4-12).
- (3) Unscrew the pipe nipple from the upper manifold (fig. 4-13).
- (4) Remove the nuts and lockwashers securing the upper manifold to the lower manifolds and braces (fig. 4-13).
- (5) Remove the cap screws and lockwashers securing the carburetor to the upper manifold (fig. 4-13).
- (6) Lift the manifold from the engine and remove the gaskets.

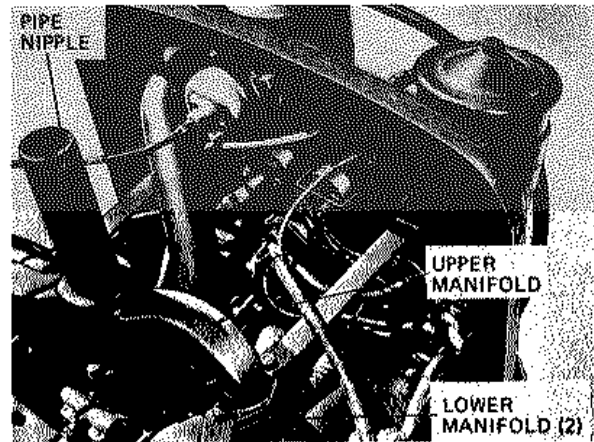

ME3895-342-12/4-13

Figure 4-13. Upper and lower manifolds removal.

b. Cleaning and Inspection.

(1) Clean all parts with a cleaning solvent or compressed air.

(2) Inspect all parts for cracks and warpage. Replace cracked or warped parts.

c. Installation. Install the upper manifold in reverse of instructions in sub paragraph a above.

Caution: Tighten the nuts for mounting the manifold to 14 to 18 footpounds torque.

4-17. Lower Manifolds

a. Removal.

(1) Remove the muffler (para 4-11).

(2) Remove the top canopy, side doors and front panel (para 4-12).

(3) Remove the upper manifold (para 4-16).

(4) Remove the nuts and lockwashers securing the lower manifolds to the engine block - fig. 4-131.

(5) Unscrew the support pin and lockwasher from the lower manifolds, and lift the lower manifolds from the engine. Remove the gaskets.

b. Cleaning and Inspection.

(1) Clean all parts with a cleaning solvent or compressed air.

(2) Inspect all parts for cracks or warpage. Replace cracked or warped parts.

c. Installation. Install the lower manifolds in reverse of the instructions in sub paragraph a above.

Caution: Tighten the nuts for mounting the manifolds to 14 to 18 foot pounds torque.

SECTION VIII. COOLING SYSTEM

4-18. General

The cooling system consists of a combination fan and flywheel which forces a flow of air through the flywheel shroud to circulate around the cylinders and cylinder heads. Air shrouds direct the flow of air.

4-19. Cylinder Air Shrouds

a. Removal.

(1) Remove the muffler (para 4-11).

(2) Remove the top canopy, side doors and front panel (para 4-12).

(3) Remove the screws securing the cylinder shrouding to the flywheel shroud (fig. 4-14).

(4) Remove the screws and clips securing the spark plug leads to the cylinder air shrouds (fig. 4-21).

(5) Remove the connecting nuts securing the spark plug leads to the spark plug (fig. 4-21).

(6) Unscrew the support pin and lockwasher from the lower manifold and lift the shrouding from the cylinders

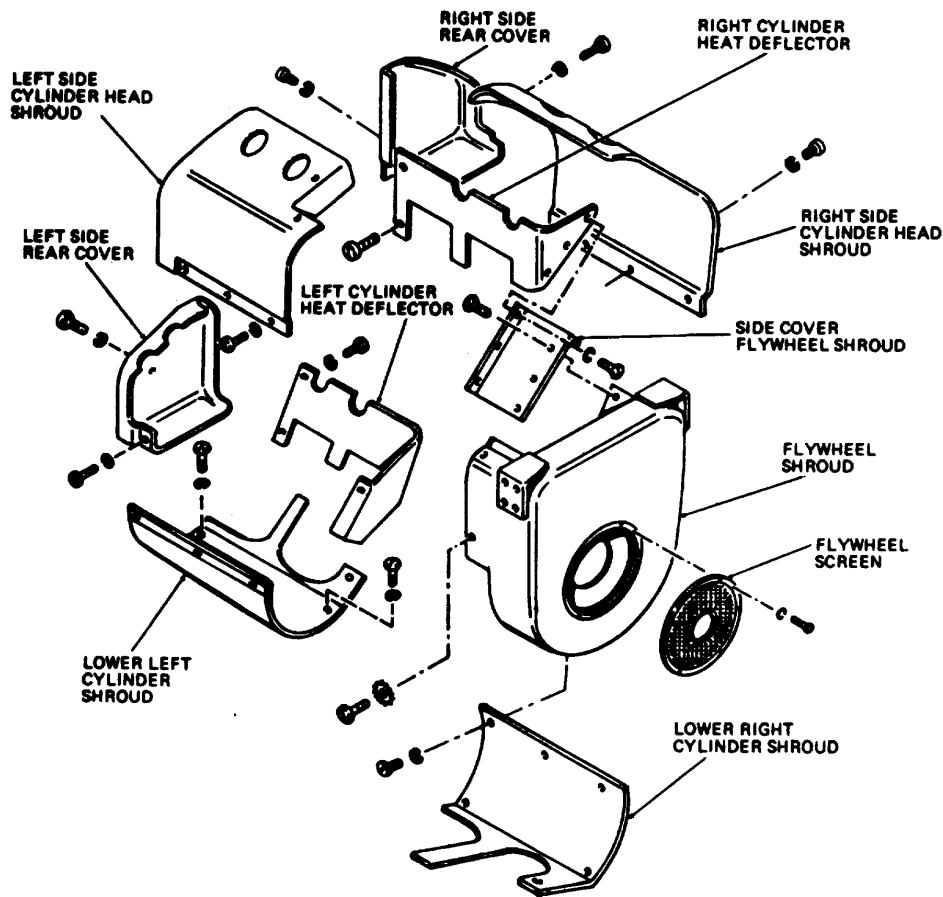

ME 3895-342-12/4-14 C1

Figure 4-14. Cylinder air shrouds, exploded view.

b. Cleaning and Inspection.

- (1) Clean all parts with a cleaning solvent.
- (2) Inspect all shrouding for excessive damage. Replace damaged shroud components as necessary.

c. Installation.

Install the cylinder air shrouding in reverse of the instructions in a above.

SECTION IX. ELECTRICAL SYSTEM

4-20. General

The electrical system is 24-volt, negative ground. It consist of a flywheel alternator with solid-state regulator, two 12-volt batteries, a starting motor, a

hi-temperature safety switch. gages. meters, and wiring. The ignition system consists of a magneto. spark plugs, ignition switch, starter switch, and shielded wiring.

4-21. Batteries and Cables

CAUTION

Disconnect battery ground cable before attempting to remove or service batteries.

a. *Removal.* Remove batteries and cables as instructed on figure 4-15.

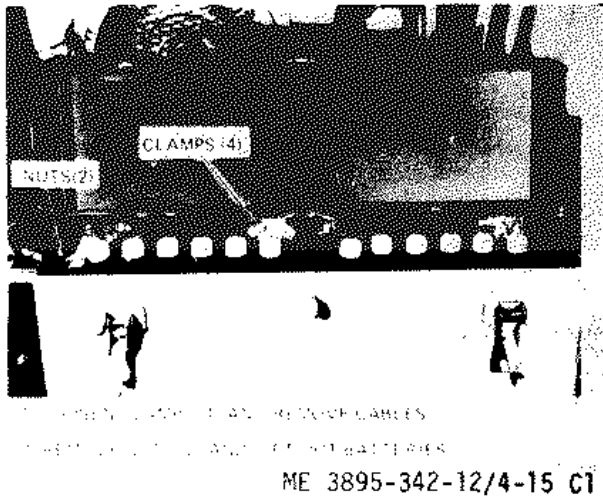

Figure 4-15. Batteries and cables removal.

b. *Cleaning and Inspection.*

- (1) Clean all parts with a cleaning solvent.
- (2) Inspect the batteries for cracks, loose or broken terminals, and other damage. Replace defective batteries.
- (3) Inspect cables for fraying, corrosion, and damage. Replace defective cables.
- (4) Refer to TM 9-6140-200-14 for servicing, testing, and charging batteries.

c. *Installation.* Install the batteries and battery cables in reverse of instructions on figure 4-15.

4-22. Battery Box

a. *Removal.*

- (1) Remove batteries and cables (para 4-21).
- (2) Remove battery box as instructed on figure 4-16.

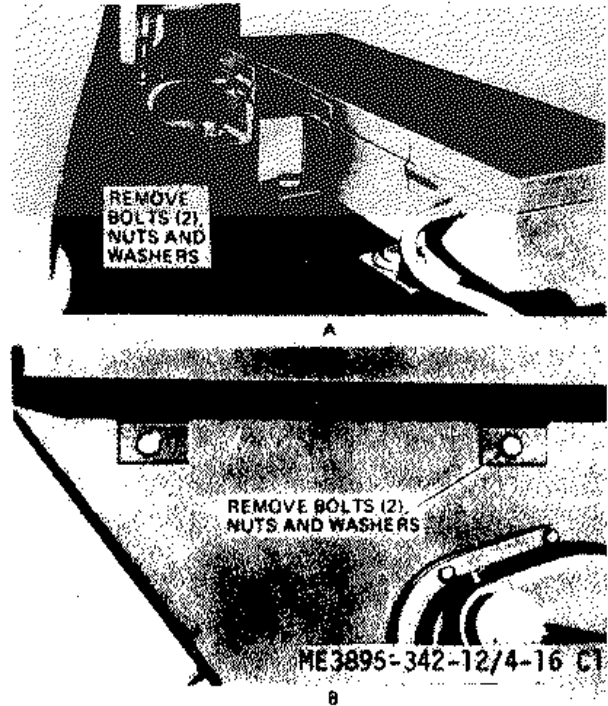

Figure 4-16. Battery box removal.

b. *Cleaning and Inspection.*

- (1) Clean all parts with a cleaning solvent.
- (2) Inspect all parts for damage. Replace damaged battery box.

c. *Installation.* Install battery box in reverse of instructions in a above.

4-23. Starting Motor

a. Removal.

(1) Remove the engine house side door nearest the drum.

(2) Remove the starting motor as instructed on figure 4-17.

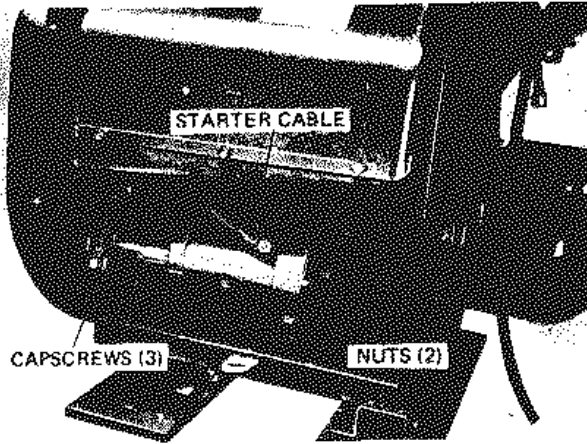

1. DISCONNECT STARTER CABLE.
2. REMOVE NUTS (2), WASHERS AND SUPPORT BRACKET.
3. REMOVE CAPSCREWS (3), WASHERS AND STARTER.

ME3896-342-1/17

Figure. 4-17. Starting motor removal.

b. Cleaning and Inspection.

(1) Clean the starting motor with a cleaning solvent.

(2) Inspect the starting motor for wear, defects, and damage. Replace a worn, defective or damaged starting motor.

c. Installation. Install the starting motor in reverse of the instructions in sub paragraph a above.

4-24. Magneto

a. Removal.

(1) Remove the engine house side door.

(2) Remove the magneto as instructed on figure 4-18.

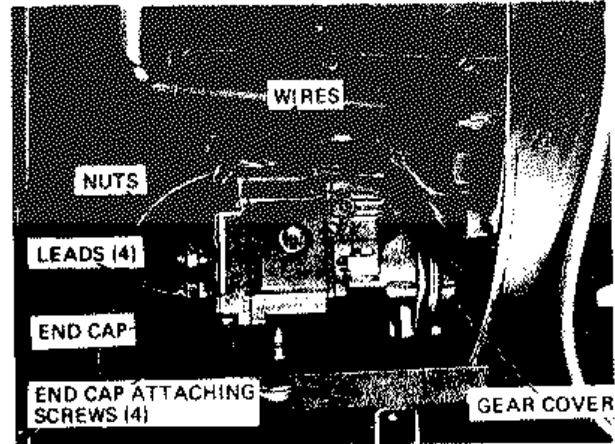

1. LOOSEN NUTS (4).
2. DISCONNECT LEADS (4).
3. DISCONNECT WIRES.
4. REMOVE NUTS, LOCKWASHERS, BOLTS FROM THE GEAR COVER AND REMOVE MAGNETO.

ME3895-342-12/4-18

Figure 4-18. Magneto removal.

b. Disassembly. Remove four screws, end cap end gasket (fig. 4-18).

c. Cleaning and Inspection.

(1) Clean all parts with a cleaning solvent. Dry thoroughly.

(2) Inspect the contact points for deep pitting or burning. Replace points as instructed on figure 4-19.

(3) Inspect the magneto for wear, defects, and damage. Replace a worn, defective or damaged magneto.

(4) Test the condenser for an open or short circuited condition. Replace if defective.

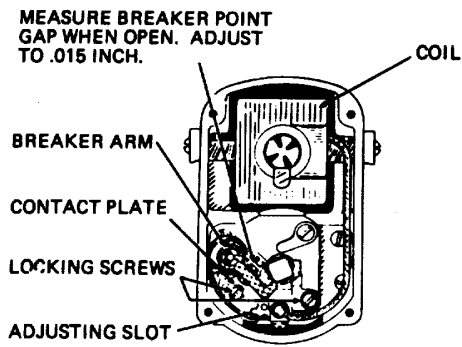

d. *Contact Point Adjustment.* Adjust the contact points as instructed on figure 4-19.

e. *Re-assembly.* Re-assemble magneto in reverse of instructions in sub paragraph b above.

f. *Timing.* Time the magneto as instructed on figure 4-20.

ME3895-342-12/4-19

Figure 4-19. Magneto contact points, replacement and adjustment.

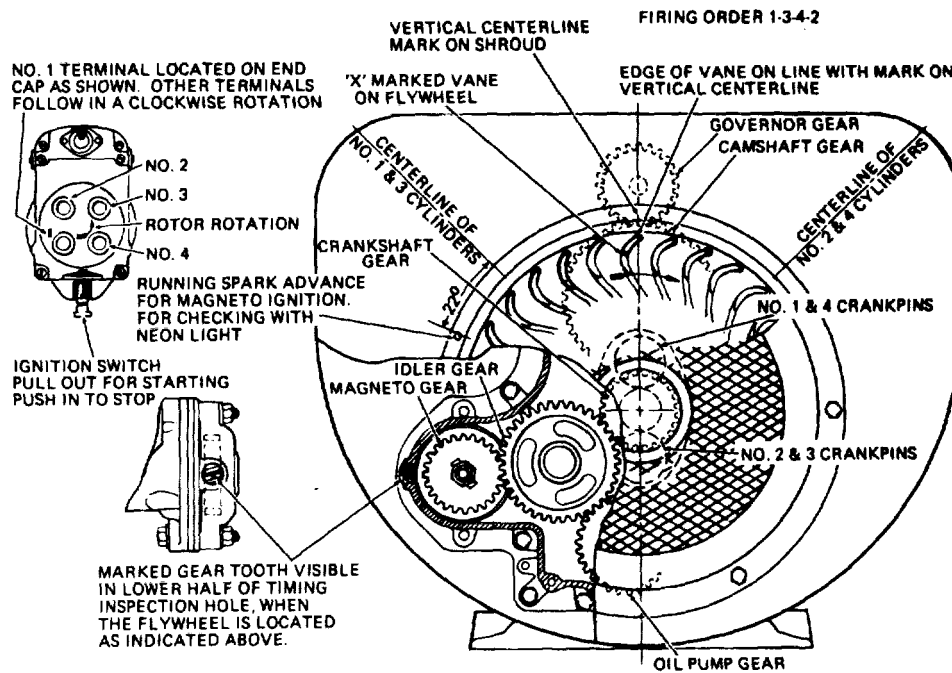

ME3895-342-12/4-20

Figure 4-20. Magneto timing.

g. Installation. Install the magneto in reverse of the instructions in sub paragraph a above.

4-25. Spark Plugs and Leads

a. Removal. Remove the spark plugs and leads as instructed on figure 4-21.

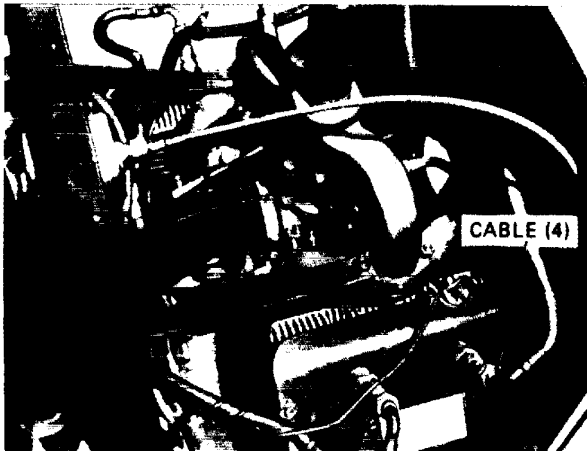

1. LOOSEN NUT AND DISCONNECT CABLE (4).
2. REMOVE SPARK PLUGS (4).

ME 3895-342-12/4-21

Figure 4-21. Spark plugs and leads removal.

b. Cleaning and Inspection.

- (1) Clean the spark plug leads with a cloth dampened in cleaning solvent and dry thoroughly.
- (2) Clean the spark plug electrodes by sand-blasting.
- (3) Inspect the spark plug electrodes for burned or tapered condition. Replace defective spark plugs.
- (4) Inspect the spark plug lead sheeting for cracks, breaks, or corrosion. Replace defective leads.

(5) Check spark plug gap. Correct gap is .030 inch.

(6) Test spark plug with a suitable tester. Replace defective spark plugs.

c. Installation. Install spark plugs and leads in reverse of instructions on figure 4-21. Tighten spark plugs to 25 to 30 foot pounds torque.

4-26. Hi-Temperature Safety Switch

a. Removal. Remove the hi-temperature safety switch as instructed on figure 4-22.

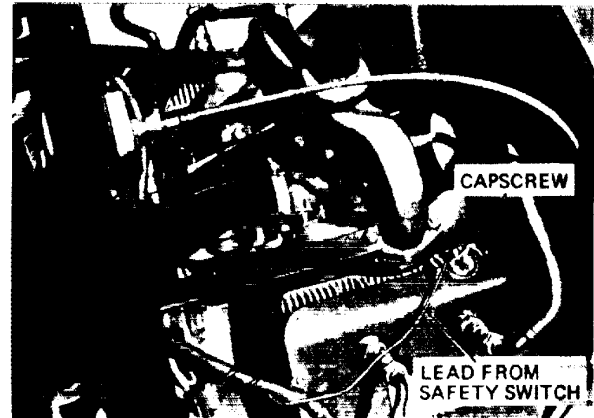

1. DISCONNECT LEAD FROM SAFETY SWITCH AND FROM MAGNETO.
2. REMOVE CAPSCREW AND WASHER AND SWITCH.

ME3895-342-1 2/4-22

Figure 4-22. Hi-temperature safety switch and lead removal.

b. Cleaning and Inspection.

- (1) Clean all parts with a cleaning solvent.
- (2) Inspect the switch for damage or corrosion. Replace a defective switch.

c. Installation. Install the hi-temperature safety switch in reverse of instructions on figure 4-22.

SECTION X. FUEL SYSTEM

4-27. General

The mixer is equipped with a gravity type fuel system. The fuel system consists of a fuel tank, air cleaner, fuel strainer and shut-off valve, carburetor, and governor. Fuel flows from the fuel tank into the fuel strainer where dirt and water in the fuel is intercepted into a removable sediment bowl. From the strainer the fuel flows into the carburetor. The

air cleaner removes dirt and grit from the air, passing clean air to the carburetor where it is mixed with the fuel for proper combustion.

4-28. Air Cleaner

a. Removal. Remove the air cleaner as instructed on figure 4-23.

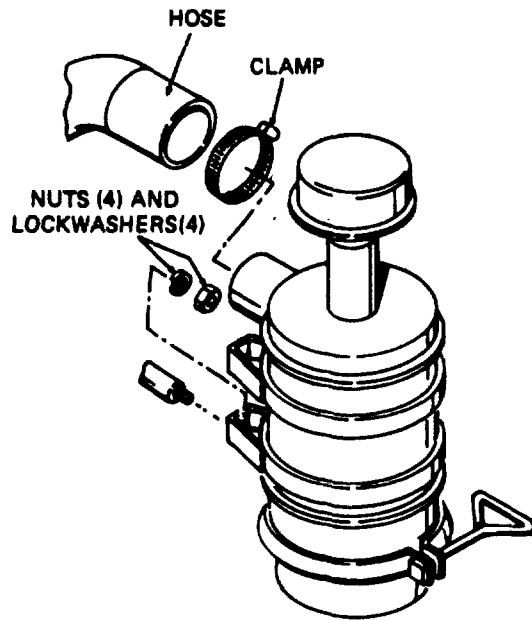

1. LOOSEN CLAMP AND DISCONNECT HOSE.
2. REMOVE NUTS (4) AND LOCKWASHERS (4) AND REMOVE AIR CLEANER.

ME3895-342-12/4-23

Figure 4-23. Air cleaner removal.

b. Disassembly. Remove the clamp, outer oil cup and inner oil cup from the air cleaner body (fig. 4-24).

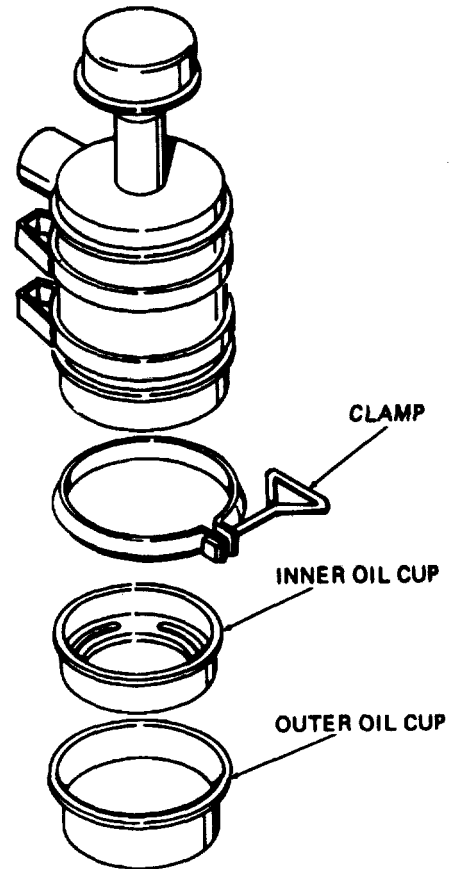

1. LOOSEN CLAMP.
2. REMOVE OUTER OIL CUP.
3. REMOVE INNER OIL CUP.

ME389342-12/4-24

Figure 4-24. Air cleaner oil cup removal.

c. Cleaning and Inspection.

- (1) Clean all parts with a cleaning solvent.
- (2) Inspect all parts for defects and damage.

Replace defective or damaged parts.

d. Re-assembly. Install the inner oil cup, outer oil cup and the clamp on the air cleaner body (fig. 4-24).

e. Installation. Install air cleaner in reverse of instructions on figure 4-23.

4-29. Fuel Strainer

a. Removal. Remove the fuel strainer as instructed on figure 4-25.

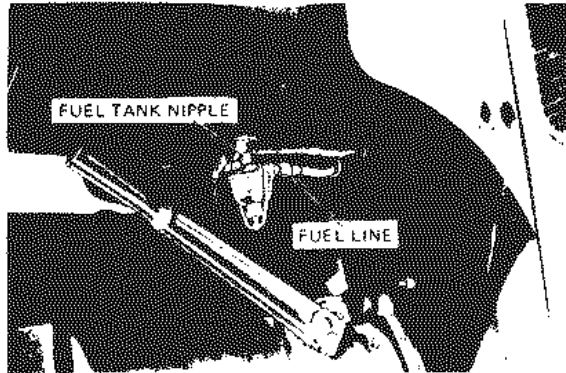

1. DRAIN FUEL FROM FUEL TANK
2. DISCONNECT FUEL LINE.
3. UNSCREW FUEL STRAINER FROM FUEL TANK NIPPLE

ME 3895 342-12 4-25 C1

Figure 4-25. Fuel strainer removal.

b. Cleaning and Inspection

- (1) Clean the fuel strainer with a cleaning solvent.
- (2) Inspect the fuel strainer for defects or damage. Replace a defective or damaged fuel strainer.

c. Installation. Install the fuel strainer in reverse of instructions on figure 4-25.

4-30. Carburetor

a. Removal.

- (1) Disconnect the choke control wire at the carburetor (fig. 4-26).
- (2) Disconnect the governor adjusting rod at the carburetor.

- (3) Disconnect the fuel line at the carburetor.
- (4) Disconnect the air hose at the carburetor.
- (5) Remove the cap screws and lockwashers securing the carburetor to the upper manifold and remove the carburetor.

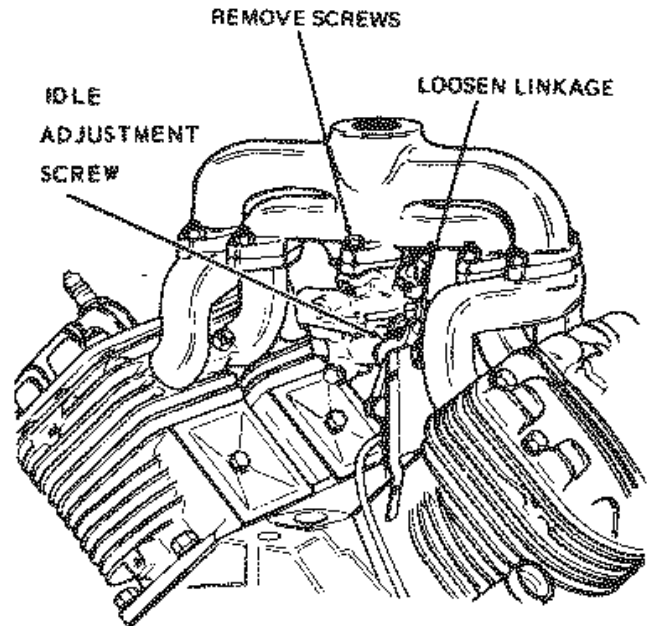

Figure 4-26. Carburetor removal.

b. Cleaning and Inspection.

- (1) Clean the carburetor with cleaning solvent and dry thoroughly with a lint-free cloth.
- (2) Inspect the carburetor for damage, loose screws, wear in the throttle valve shaft, and other defects. Replace a defective carburetor.

c. Installation. Install the carburetor in reverse of instructions in a above.

d. Adjustments.

- (1) Start the engine and allow it to reach operating temperature.
- (2) With the carburetor throttle closed, turn the idling screw (fig. 4-26) to the left until the engine starts to fail, then turn the screw to the right until the engine runs smoothly.

4-31. Fuel Level Sending Unit

a. Removal. Remove the fuel level sending unit as instructed on figure 4-27.

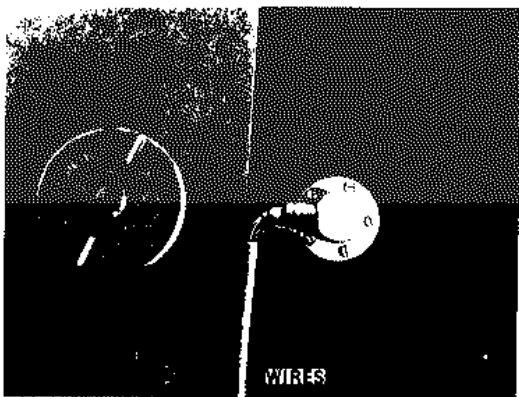

1. DISCONNECT WIRES.
 2. REMOVE REMAINING SCREWS (4) AND SENDING UNIT.
- ME 3895-342-12/4-27 C1

Figure 4-27. Fuel level sending unit removal.

b. Cleaning and Inspection.

- (1) Clean the fuel level sending unit with a cleaning solvent.
- (2) Inspect the fuel level sending unit for damage. Replace a damaged fuel level sending unit.

c. Installation. Install the fuel level sending unit in reverse of instructions on figure 4-27.

4-32. Fuel Tank

a. Removal.

- (1) Remove fuel strainer (para 4-29).

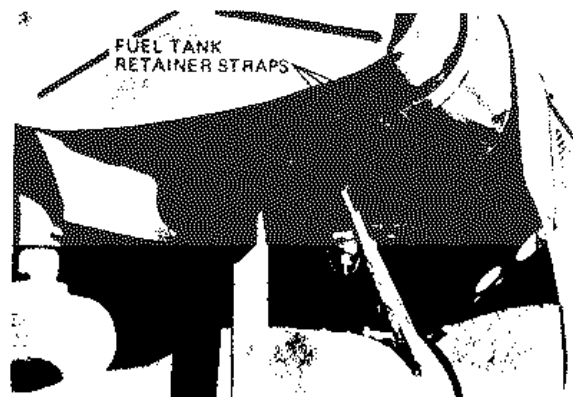

REMOVE CAPSCREWS, NUTS AND WASHERS FROM FUEL TANK RETAINER STRAPS AND REMOVE FUEL TANK.

ME 3895-342-12/4-28 C1

Figure 4-28. Fuel tank removal.

b. Cleaning and Inspection.

- (1) Clean all parts with a cleaning solvent.
- (2) Inspect the fuel tank for leaks and damage. Replace leaking or damaged fuel tank.

c. Installation. Install the fuel tank in reverse of instructions in a above.

Section XI. LUBRICATION SYSTEM

4-33. General

The lubrication system consists of an oil pump, oil filter, and an oil pressure relief valve. The pump supplies oil to four nozzles which direct oil streams against fins on the connecting rod caps. Part of the oil enters the rod bearing through holes in the rod, and the balance of the oil forms a spray or mist which lubricates and cylinders and other internal parts of the engine. An external oil line from the oil header tube in the crankcase lubricates the governor and the gear train.

4-34. Oil Filter

a. Removal. Remove the oil filter. lines. And fittings as instructed on figure 4-29.

b. Remove the cover thru-bolt and disassemble oil filter. Discard element and gasket.

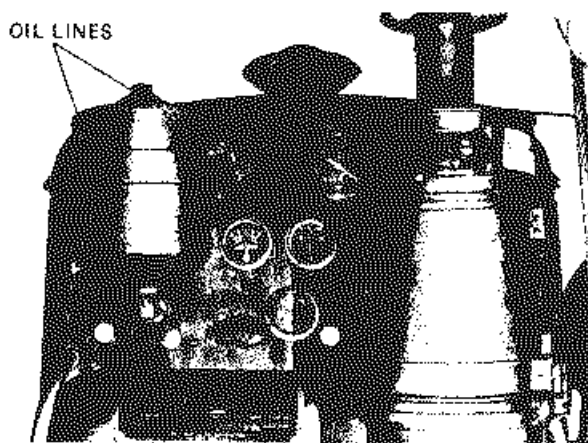

1. DISCONNECT OIL LINES.
2. REMOVE CAPSCREWS (4), WASHERS (4), LOCKWASHERS (4), NUTS (4) AND OIL FILTER.

ME 3895-342-12/4-29 C1

Figure 4-29. Oil filter removal.

c. Cleaning and Inspection.

- (1) Clean all parts with a cleaning solvent.
- (2) Inspect the filter and all lines and fittings for cracks, bends, or breaks. Replace defective parts.

d. Installation. Reassemble oil filter using new element and gasket. Install the oil filter, lines, and fittings in reverse of instructions on figure 4-29.

4-35. Oil Filler Cap

a. Removal. Remove the oil filler cap (fig. 4-30) from the filler tube.

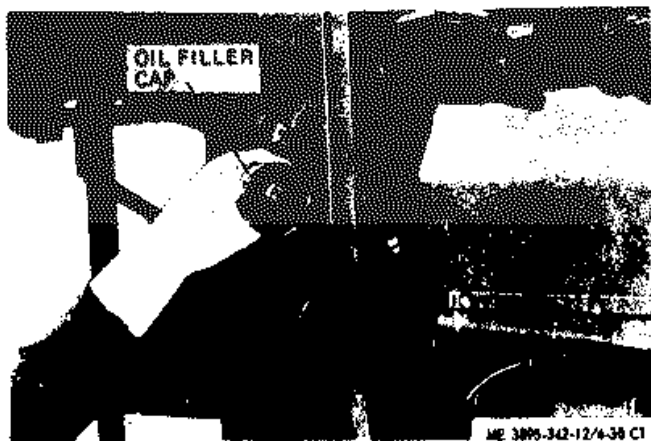

Figure 4-30. Oil filler cap.

b. Cleaning and Inspection.

- (1) Clean the oil filler cap with a cleaning solvent.

- (2) Inspect the cap for damage. Replace a damaged filler cap.

c. Installation. Install the oil filler cap on the filler tube.

4-36. Oil Filler Tube Strainer

a. Removal. Remove the oil filler tube strainer as instructed on figure 4-31.



Figure 4-31. Oil filler tube strainer removal.

b. Cleaning and Inspection.

- (1) Clean all parts with a cleaning solvent.
- (2) Inspect all parts for defects and damage. Replace defective or damaged parts.

c. Installation. Install the oil filler tube strainer in reverse of the instructions on figure 4-31.

Section XII. ENGINE CONTROL, METERS, AND GAGES

4-37. General

The engine controls, meters, and gages consist of a choke control, governor control, ignition switch, starter switch, fuel level gage, oil pressure gage, ammeter, and hour meter-tachometer. The engine controls, meters, and gages are located in the engine housing front panel.

4-38. Choke Control

a. Removal. Remove the choke control as instructed on figure 4-32.

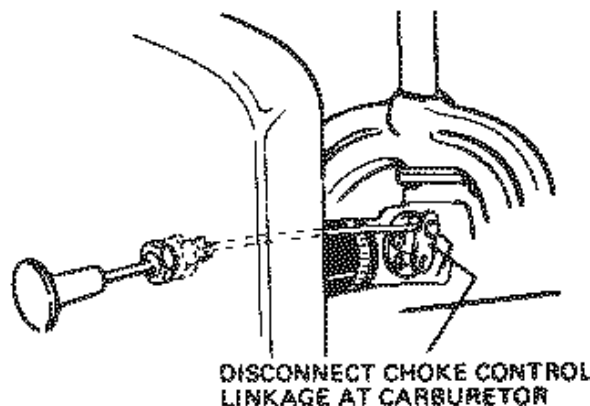

ME 3895-342-12/4-32 C1

Figure 4-32. Choke control removal.

b. Cleaning and Inspection.

- (1) Clean all parts with a cleaning solvent.
- (2) Inspect all parts for wear or damage.
Replace worn or damaged parts.

c. Installation. Install the choke control in reverse of the instructions on figure 4-32.

4-39. Governor Control

a. Removal. Remove the governor control as instructed on figure 4-33.

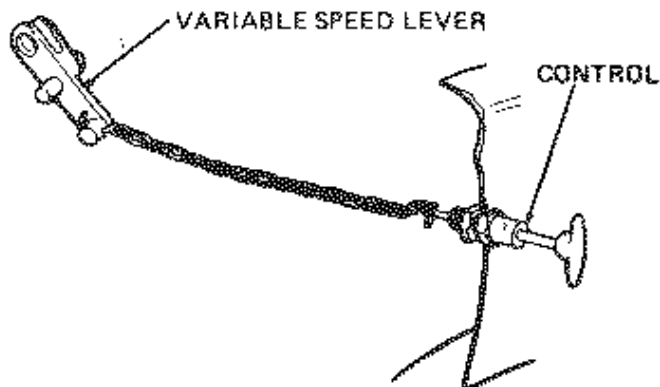

1. DISCONNECT CHAIN AT VARIABLE SPEED LEVER AND AT CONTROL.
2. REMOVE LOCKNUT AND CONTROL.

ME 3895-342-12/4-33 C1

Figure 4-33. Governor control removal.

b. Cleaning and Inspection

- (1) Clean all parts with a cleaning solvent.
- (2) Inspect all parts for wear or damage.
Replace worn or damaged parts.

c. Installation. Install the governor control in reverse of the instructions on figure 4-33.

4-40. Ignition Switch

a. Removal. Remove the ignition switch as instructed on figure 4-34.

TAG AND DISCONNECT ELECTRICAL LEADS AND REMOVE ATTACHING HARDWARE.
NOTE: REMOVE OTHER METERS, SWITCHES, AND GAGES IN SIMILAR MANNER.



Figure 4-34. Meters and gages removal.

b. Cleaning and Inspection.

- (1) Clean all parts with a cleaning solvent.
- (2) Inspect all parts for wear or damage.
Replace worn or damaged parts.

c. Installation. Install the ignition switch in reverse of the instructions on figure 4-34.

4-41. Start Switch

a. Removal. Remove the start switch as instructed on figure 4-34.

b. Cleaning and Inspection.

- (1) Clean all parts with a cleaning solvent.
- (2) Inspect all parts for wear or damage.
Replace worn or damaged parts.

c. Installation. Install the start switch in reverse of the instructions on figure 4-34.

4-42. Fuel Level Gage

a. Removal. Remove the fuel level gage as instructed on figure 4-34.

b. Cleaning and Inspection.

- (1) Clean all parts with a cleaning solvent.
- (2) Inspect all parts for wear or damage.
Replace worn or damaged parts.

c. Installation. Install the fuel level gage in reverse of the instructions on figure 4-34.

4-43. Oil Pressure Gage

a. Removal. Remove the oil pressure gage as instructed on figure 4-34.

b. Cleaning and Inspection.

- (1) Clean all parts with a cleaning solvent.
- (2) Inspect all parts for wear or damage.
Replace worn or damaged parts.

c. Installation. Install oil pressure gage in reverse of the instructions on figure 4-34.

4-44. Ammeter

a. Removal. Remove the ammeter as instructed on figure 4-34.

b. Cleaning and Inspection.

- (1) Clean all parts with a cleaning solvent.
- (2) Inspect all parts for wear or damage.
Replace worn or damaged parts.

c. Installation. Install the ammeter in reverse of the instructions on figure 4-34.

4-45. Hour Meter-Tachometer

a. Removal. Remove the hour meter-tachometer as instructed on figure 4-34.

b. Cleaning and Inspection.

- (1) Clean all parts with a cleaning solvent.
- (2) Inspect all parts for wear or damage.
Replace worn or damaged parts.

c. Installation. Install the hour meter-tachometer on reverse of the instructions on figure 4-34.

Section XIII. CLUTCH ASSEMBLY

4-46. General

The clutch is housed in a power transfer case on the engine crankshaft. It is a wet-type disk clutch which is operated by a clutch lever and yoke mechanism.

4-47. Clutch Adjustment

a. Remove the clutch inspection plate (fig. 4-35).



ME3895-342-12/4-35

Figure 4-35. Clutch adjustment.

b. Release the clutch by pushing the clutch lever toward the engine.

c. Turn the engine over until the clutch adjustment lock is visible through the inspection opening (fig. 4-35). Loosen the adjustment lock screw one full turn.

d. While keeping the engine crankshaft from turning, turn the notched adjusting ring (fig. 4-35) one notch at a time in a clockwise direction, until a very firm pressure is required to engage the clutch with the lever. The clutch will snap into engaged position, when it is correctly adjusted.

e. Securely tighten adjustment lock screw.

f. Install inspection plate being sure that the gasket fits properly and is not broken.

Section XIV. WATER SYSTEM

4-48. General

The water system consists of an automatic siphon cut-off type tank, a water pump, and a three-way valve. The amount of water discharged into the drum is pre-determined by the operator by setting the indicator lever on the graduated quadrant. This lever moves the siphon head up or down to regulate the exact amount of mixing water desired.

4-49. Pump Belt

a. *Removal.*

- (1) Remove belt guard as instructed on figure 4-5.
- (2) Remove the pump belt as instructed on figure 4-36.

NOTE: ADJUST BELT AFTER INSTALLATION TO 1/2 INCH DEFLECTION MID WAY BETWEEN SHEAVES.

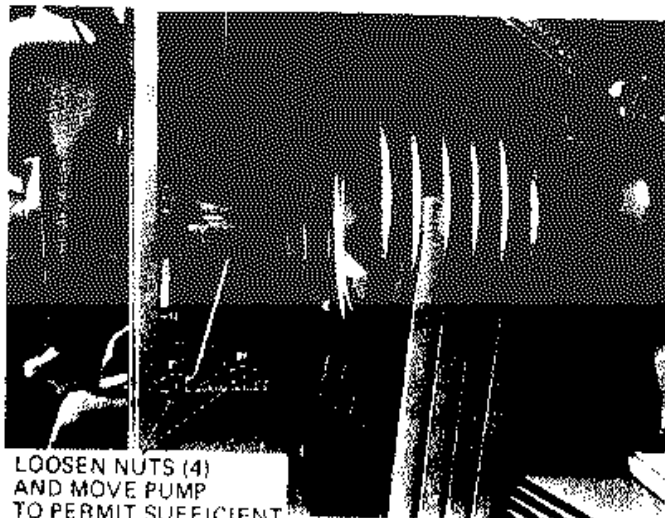

LOOSEN NUTS (4)
AND MOVE PUMP
TO PERMIT SUFFICIENT
SLACK IN BELT TO
PERMIT REMOVAL.

ME3895-342-12/4-36

Figure 4-36. Pump belt removal.

ME3895-342-12/4-36

b. *Inspection.* Inspect the belt for excessive wear and fraying. Replace belt as necessary.

c. *Installation.* Install the pump belt in reverse of instructions in sub paragraph a above.

d. *Adjustment.* Adjust the pump belt as instructed on figure 4-36.

4-50. Pump

a. *Removal.*

- (1) Remove the pump belt (para 4-49).
- (2) Remove the pump as instructed on figure 4-37.

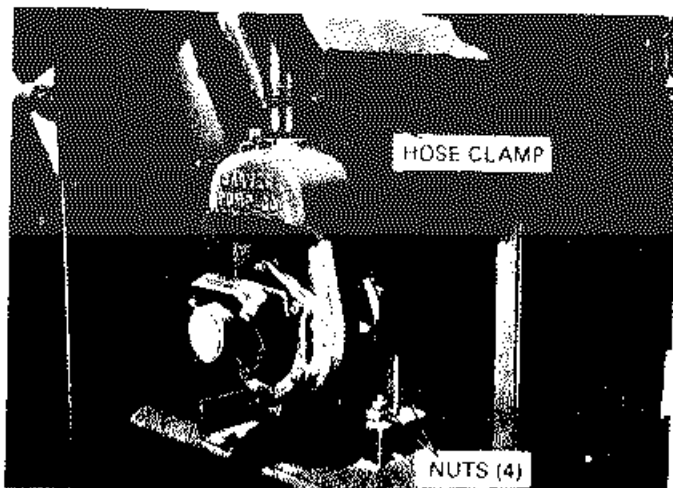

1. LOOSEN HOSE CLAMP AND DISCONNECT HOSE.
2. REMOVE NUTS (4), WASHERS AND BOLTS, AND REMOVE PUMP.

ME3895-342-12/4-37

Figure 4-37. Pump removal.

b. *Cleaning and Inspection.*

- (1) Clean all parts with a cleaning solvent.
- (2) Inspect pump for cracks and other defects. Replace defective pump.

c. *Installation.* Install the pump in reverse of instructions on figure 4-37.

4-51. Three-Way Valve

a. *Removal.* Remove the three-way valve as instructed on figure 4-38.

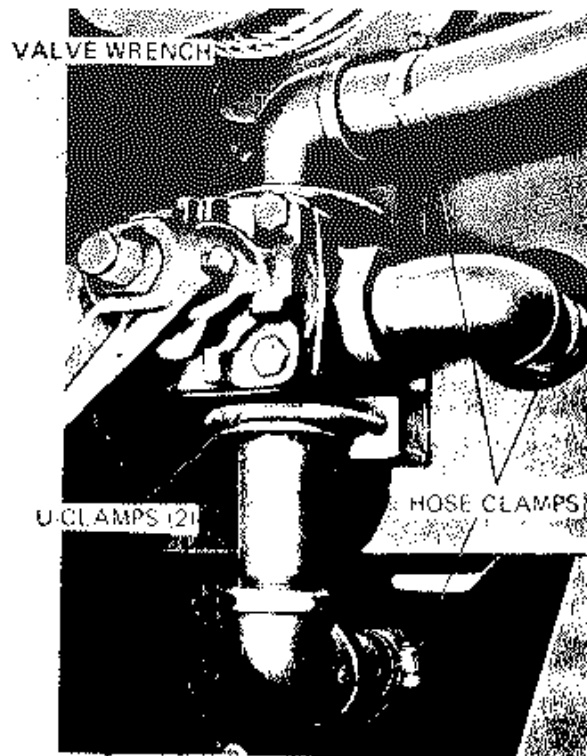

1. LOOSEN SETSCREW AND REMOVE VALVE WRENCH.
2. LOOSEN HOSE CLAMPS AND DISCONNECT HOSES.
3. REMOVE NUTS (4) AND WASHERS SECURING U-CLAMPS (2) AND REMOVE VALVE.

ME3895-342-12/4-38

Figure 4-38. Three-way valve removal.

b. *Cleaning and Inspection.*

- (1) Clean the valve with a cleaning solvent.
- (2) Inspect the valve for leaks, cracks and other defects. Replace a defective valve.

c. *Installation.* Install the valve in reverse of instructions on figure 4-38.

Section XV. HOIST CABLE

4-52. Hoist Cable

a. Removal.

- (1) Lower skip to the ground.
- (2) Hold clutch open and pull hoist cable out by hand as far as possible.
- (3) Remove the hoist cable as instructed on figure 4-39.

b. Cleaning and Inspection.

- (1) Clean the hoist cable by brushing with a cleaning solvent.
- (2) Inspect the hoist cable for wear, fraying, and corrosion. Replace excessively worn or frayed cable.

c. Installation. Install the hoist cable in reverse of the instructions on figure 4-39.

Important. Provide at least one full turn of the cable on the pulley when the skip is down, and one full turn of the cable on the cable drum when the skip is at its top position.

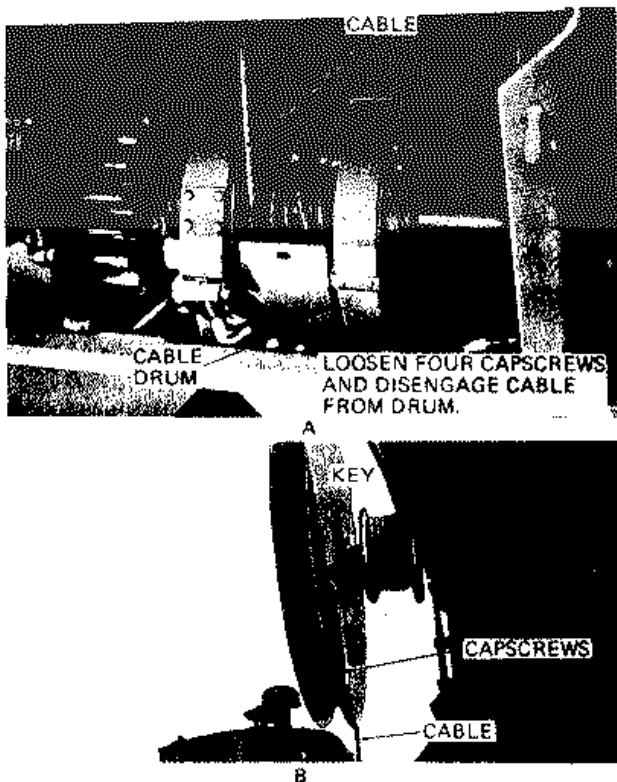

ME3895-342-1 2/4-39

1. REMOVE KEY.
2. PULL CABLE OFF PULLEY AS FAR AS POSSIBLE. DO NOT LET PULLEY SLIDE OFF SHAFT.
3. LOOSEN CAPSCREWS (2) AND DISENGAGE CABLE FROM PULLEY.

- A. Hoist cable removal
- B. Hoist cable removal

Figure 4-39. Hoist cable removal.

Section XVI. HAULING STUB SAFETY CHAIN

4-53. Hauling Stub Safety Chain

a. Removal. Remove the hauling stub safety chain as instructed on figure 4-40.

b. Cleaning and Inspection.

- (1) Clean the safety chain with a cleaning solvent.

- (2) Inspect the safety chain for wear, broken links, and corrosion. Replace worn or broken chain links.

c. Installation. Install the safety chain in reverse of the instructions on figure 4-40.

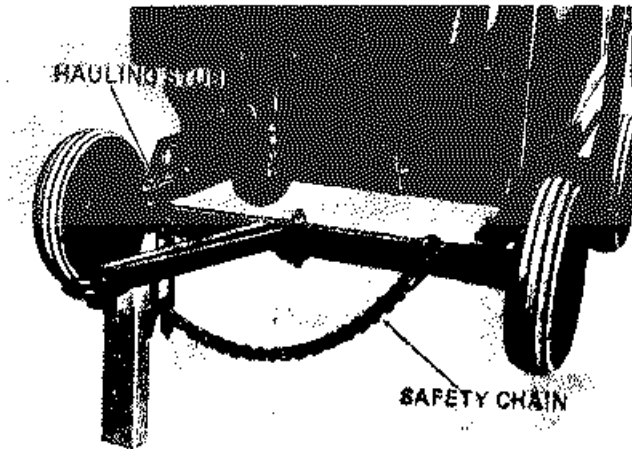

1. DISCONNECT SAFETY CHAIN FROM FRAME.
 2. DISENGAGE CHAIN FROM HAULING STUB.
- ME3895-342-12/4-40

Figure 4-40. Hauling stub safety chain.

Section XVII. WHEEL ASSEMBLY

4-54. Wheel Assembly

a. *Removal.* Remove wheel assembly in numerical sequence as illustrated in figure 4-41.

b. *Cleaning, Inspection, and Repair.*

(1) Clean all parts with a cleaning solvent.

(2) Inspect all parts for wear and damage.

(3) Repair or replace worn or damaged parts.

c. *Installation.* Install wheel assembly in reverse of instructions in figure 4-41.

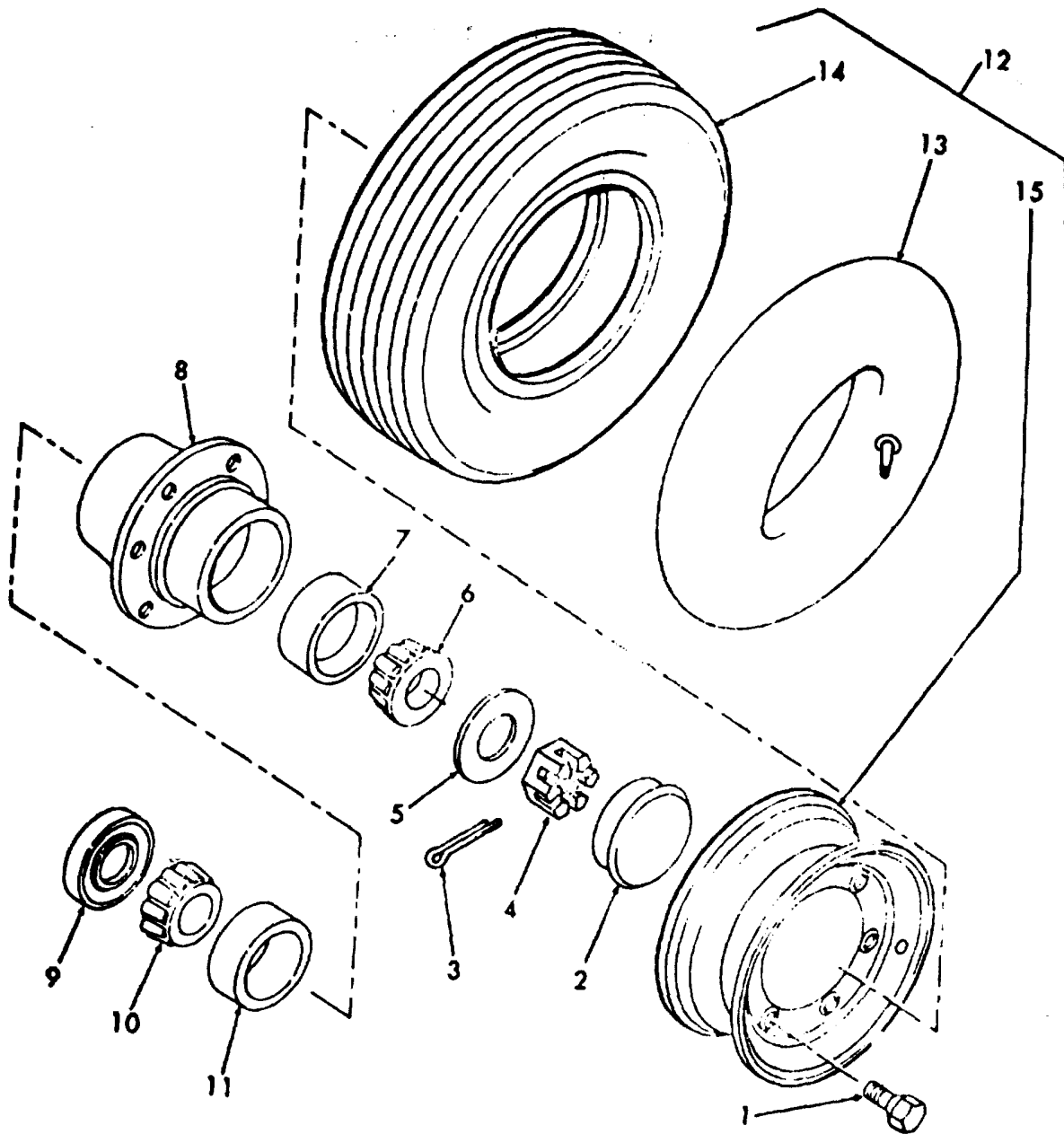

ME3895-342 34 9 1

- | | | |
|-----------------------|------------------|------------------------|
| 1 Bolt | 6 Bearing, cone | 11 Cup, bearing |
| 2 Cap | 7 Cup, bearing | 12 Tire and wheel Assy |
| 3 Pin, cotter | 8 Hub | 13 Tube, inner |
| 4 Nut, castelated hex | 9 Seal | 14 Tire |
| 5 Washer | 10 Cone, bearing | 15 Rim, wheel |

Figure 4-41. Wheel assembly, exploded view.

CHAPTER 5
ADMINISTRATIVE STORAGE

To insure adequate protection of the mixer during storage, follow instructions given in TM 740-9-1. Administrative Storage of Equipment.

**APPENDIX A
REFERENCES**

A-1. Fire Protection

TB 5-4200-200-10

Hand Portable Fire Extinguishers Approved For Army Users

A-2. Lubrication

C9100-IL

LO 5-3895-342-12-1

LO 5-3895-342-12-2

Identification List for Fuels, Lubricants, Oils and Waxes

Lubrication Order Mixer, Concrete, T. L. Smith Model 499A

Lubrication Order Mixer, Concrete, T. L. Smith Model 499A

A-3. Painting

TM 9-213

Painting Instructions for Field Use

A-4. Radio Suppression

TM 11-483

Radio Interference Suppression

A-5. Maintenance

TM 9-2610-200-20

TM 38-750

TM 5-3895-342-12

TM 5-3895-342-20P

TM 9-6140-200-14

Organizational Care and Maintenance of Pneumatic Tires and Inner Tubes

The Army Maintenance Management System (TAMMS)

Operator and Organizational Maintenance Manual

Organizational Maintenance Repair Parts and Special Tools List

Operation and Organizational, Field and Depot Maintenance: Storage

Batteries, Lead Acid Type

A-6. Shipment and Storage

TB 740-97-2

TM 740-90-1

Preservation of USAMEC Mechanical Equipment for Shipment and Storage

Administrative Storage of Equipment

A-7. Destruction to Prevent Enemy Use

TM 750-244-3

Procedures for Destruction of Equipment to Prevent Enemy Use

APPENDIX B MAINTENANCE ALLOCATION CHART

Section I. INTRODUCTION

B-1. General

a. This section provides a general explanation of all maintenance and repair functions authorized at various maintenance levels.

b. Section II designates overall responsibility for the performance of maintenance functions on the identified end item or component. The implementation of the maintenance functions upon the end item or component will be consistent with the assigned maintenance functions.

c. Section III lists the special tools and test equipment required for each maintenance function as referenced from section II.

d. Section IV contains supplemental instructions or explanatory notes required for a particular maintenance function.

B-2. Explanation of Columns in Section II

a. Group Number, Column (1). The assembly group number is a numerical group assigned to each assembly. The assembly groups are listed on the MAC in disassembly sequence beginning with the first assembly removed in a top down disassembly sequence.

b. Assembly Group, Column (2). This column contains a brief description of the components of each assembly group.

c. Maintenance Functions, Column (3). This column lists the various maintenance functions (A through K). The upper case letter placed in the appropriate column indicates the lowest maintenance level authorized to perform these functions. The symbol designations for the various maintenance levels are as follows:

- C-Operator or crew
- O-Organizational maintenance
- F-Direct support maintenance
- H-General support maintenance
- D-Depot maintenance

The maintenance functions are defined as follows:

A-Inspect. To determine serviceability of an item by comparing its physical, mechanical, and electrical characteristics with established standards.

B-Test. To verify serviceability and to detect electrical or mechanical failure by use of test equipment.

C-Service. To clean, to preserve, to charge, and to add fuel, lubricants, cooling agents, and air. (If it is desired that elements, such as painting and lubricating, be defined separately, they may be so listed.)

D-Adjust. To rectify to the extent necessary to bring into proper operating range.

E-Align. To adjust specified variable elements of an item to bring to optimum performance.

F-Calibrate. To determine the corrections to be made in the readings of instruments or test equipment used in precise measurement. Consists of the comparison of two instruments, one of which is a certified standard of known accuracy, to detect and adjust any discrepancy in the accuracy of the instrument being compared with the certified standard.

G-Install. To set up for use in an operational environment such as an emplacement, site, or vehicle.

H-Replace. To replace unserviceable items with serviceable like items.

I-Repair. Those maintenance operations necessary to restore an item to serviceable condition through correction of material damage or a specific failure. Repair may be accomplished at each level of maintenance.

J-Overhaul. Normally, the highest degree of maintenance performed by the Army in order to minimize time work is in process consistent with quality and economy of operation. It consists of that maintenance necessary to restore an item to completely serviceable condition as prescribed by maintenance standards in technical publications for each item of equipment. Overhaul normally does not return an item to like new, zero mileage, or zero hour condition.

K-Rebuild. The highest degree of materiel maintenance. It consists of restoring equipment as nearly as possible to new condition in accordance with original manufacturing standards. Rebuild is performed only when required by operational considerations or other paramount factors and then only at the depot maintenance level. Rebuild reduces to zero the hours or miles the equipment, or component thereof, has been in use.

d. Tools and Equipment. Column (4). This column is provided for referencing by code the special tools and test equipment (sec. III), required to perform the maintenance functions (sec. II).

e. Remarks. Column (5). This column is provided for referencing by code the remarks ,sec. IV) pertinent to the maintenance functions.

B-3. Explanation of Columns in Section III

a. Reference Code. This column consists of a number and a letter separated by a dash. The number, references the T&TE requirements listed in section II. The letter represents the specific maintenance function the item is to be used with in columns A through K of section II.

b. Maintenance Level. This column shows the lowest level of maintenance authorized to use the special tool or test equipment.

c. Nomenclature. This column lists the name or identification of the tool or test equipment.

d. Tool Number. This column lists the manufacturer's code and part number, or Federal stock number of tool or test equipment.

B-4. Explanation of Columns in Section IV

a. Reference Code. This column consists of two letters separated by a dash (entered for Col. 5 of sec. II). The first letter references alpha sequence in column (5) and the second letter references a maintenance function, column (3), A through K.

b. Remarks. This column lists information pertinent to the maintenance function to be performed (as indicated in sec. II).

Section II. MAINTENANCE ALLOCATION CHART

(1) Group No.	(2) Functional group	(3) Maintenance functions										(4) Tools and equipment	(5) Remarks	
		A	B	C	D	E	F	G	H	I	J			K
		Inspect	Test	Service	Adjust	Align	Calibrate	Install	Replace	Repair	Overhaul			Rebuild
01	ENGINE ASSY, POWER UNIT	C	O	C	O	O			F	O	H	D		
	Air Cleaner Assy	O		C	O	O			F	O				
	Filter Assy, Oil	O		O					F	O				
	Element, Oil Filter								F	O				
	Muffler & Flanges	C							O					
	Hood, Engine	C							O					
	Fuel Tank & Cowl	C		C					O					
	Carburetor Assy	O			O				O	F				
	Float, Carburetor	F			F				F					
	Manifold, Int & Exh	O							O					
	Filter Assy, Fuel	C		C					O					
	Starter Assy, Engine	O	O						O	F				
	Switch, Solenoid	O	O						O					
	Rotor	F	F						F	F				
	Gear Assy, Starter	F							F					
	Stator	F	F						F					
	Brushes	F							F					
	Magneto	O	O	O	O				O	F				
	Contact Points	O			O				O					
	Capacitor	O	O						O					
	Coil, Magneto		F						F					
	Bearings	F							F					
	Leads, Spark Plug	O	O						O					
	Spark Plugs	O	O						O					
	Governor Assy	O	F		O				O	F				
	Bearings	F							F					
	Linkage & Spring	O			F				O					
	Breather, Oil Filter	C		C					O					
	Strainer, Oil Fill Tube	O		O					O					
	Meters & Gages	C	O						O					
	Choke Control	C			O				O					
	Control, Governor	C			C				O					
	Panel, Instrument	C							O					
	Clutch Reduction Gear Assy	O	O	O	O				F	F				
	Clutch Assy	O	O		O				F	F				
	Disk, with Facing	F							F	F				
	Pressure Plate & Lever Assy	F							F					
	Sleeve Assy, Release	F							F	F				
	Bearing Release	F							F					
	Bearing, Shaft	F							F					
	Springs, Return	F							F					
	Housing, Clutch	F							F					
	Reduction Gear Assy	F		O	F				F	F				
	Cover	F							F					
	Shaft and Bearings	F			F				F					
	Sprockets and Chain	F							F					
	Seals, Oil	F							F					
	Flywheel	O							F					
	Stator, Alternator	F	F						F					
	Rectifier	F	F						F					
	Regulator, Voltage	F	F						F					
	Shroud & Ducts, Cooling	O							F	O				
	Head, Cylinder	F							F					
	Pan, Oil	F							F					
	Strainer, Oil Pump	F		F					F					
	Cover, Gear	H							H					
	Seal, Oil, Crankshaft	H							H					
	Gear, Oil Pump Drive	H							H					
	Pump, Oil	H	F						H	H				
	Gears & Shafts, Oil Pump	H							H					

Section II. MAINTENANCE ALLOCATION CHART
Section II. MAINTENANCE ALLOCATION CHART

(1) Group No.	(2) Functional group	(3) Maintenance functions											(4) Tools and equipment	(5) Remarks			
		A	B	C	D	E	F	G	H	I	J	K					
		Inspect	Test	Service	Adjust	Align	Calibrate	Install	Replace	Repair	Overhaul	Rebuild					
01	ENGINE ASSY, POWER UNIT— Continued																
	Piston, Conn Rod Assy	H							H	H							
	Pin, Piston	H							H	H							
	Rod Assy, Connecting	H							H	H							
	Bearing, Piston Pin	H							H	H							
	Bearing, Conn Rod	F							F	H							
	Piston Assy	H							H	H							
	Rings, Piston	H			H				H	H							
	Gears, Idler & Camshaft	H			H				H	H							
	Bearing Plate, Crank	H			H				H	H							
	Crankshaft Assy	H							H	H							
	Gear, Crankshaft	H							H	H							
	Bearings, Crankshaft	H			H				H	H							
	Cylinder Block Assy	F			O				H	O	F						
	Cover, Valve Tappets	O							O	F							
	Springs, Valve	F							O	F							
	Valves, Int. & Exh.	F			O				F	F							
	Guides, Valve Stem	H				H			H	H							
	Seats, Valve, Int. & Exh.	H							H	H							
	Camshaft	H							H	H							
	Tappets, Valve	H							H	H							
	Crankcase Assy	H							H	H							
02	TANK & PIPING ASSY	O							H	O							
	Valve Check	O		O					O	O							
	Gaskets	O							O	O							
	Tank	O		O					O	F							
	Controls	C			O				F	F							
	Gauge	C							F	O							
	Hose & Clamps	C							O	O							
	Pipe Fittings	C							O	O							
	Valve Angle	O							O	O							
	Pump, Water	C							O	O							
	Sheave, Drive	C							O	O							
	Belt, Drive	C			O				O	O							
03	DISCHARGE ASSY	C		C					F	F							
	Wheel Hand								F	F							
	Gear	F							F	F							
	Shaft & Pinion	F							F	F							
	Gear Case	F							F	F							
	Linkage	F							F	F							
	Bearings			C					F	F							
	Shaft	F							F	F		F					
	Chute Discharge	O							F	F		F					
	Guard, Splash	O							F	F		F					
04	SKIP & DRIVE ASSY	C		C					H	F							
	Skip	C							F	F		F					
	Bearings	O		O					F	F		F					
	Spring Vibrator								F	F		H					
	Vibrator, Housing			C					H	H		H					
	Jaw Vibrator								H	H		H					
	Shaft								H	H		H					
	Gasket								H	H		H					
	Bearings								H	H		H					
	Seal								H	H		H					
	Cable	C							F	F		F					

Section II. MAINTENANCE ALLOCATION CHART
Section II. MAINTENANCE ALLOCATION CHART

(1) Group No.	(2) Functional group	(3) Maintenance functions											(4) Tools and equipment	(5) Remarks				
		A	B	C	D	E	F	G	H	I	J	K						
		Inspect	Test	Service	Adjust	Align	Calibrate	Install	Replace	Repair	Overhaul	Rebuild						
05	FRAME, ASSY UPPER	O							H	F								
	Hoist, Assy	O		C					H	F								
	Drum, L. H.								H									
	Bearing	H		C					H									
	Drum, R. H.								H									
	Bearing	H		C					H									
	Pulley	O							H									
	Shaft	O							H									
	Cable	C							O									
	Frame Uprights	C							O	F								
	Guards	C							O									
06	DRUM & ROLLERY ASSY	C		C					H	H	F							
	Drum, Mixer	C							H	F	F							
	Plate, Drum	C							F									
	Gear, Ring	C		C					F									
	Bearing, Roller	O		C					F									
	Bearing, Ball	O		O					F									
	Seal, Oil	O							F									
	Rollers, Drum	O							F									
Shaft, Drum Roller	O							F										
07	FRAME ASSY LOWER	O		C					H	F	H							
	Sheave	C							F		H							
	Springs, Chassis	F							F									
	Bearings, Ball	F							F									
	Pinion & Shaft	H							H									
	Gear	H							H									
	Case, Gear Reduction	O		C					H									
	Cover & Gasket	F							F									
	Bearing	H							H									
	Pinion, Drum	F							H									
	Collar	F							H									
	Band Clutch	F							F									
	Band Brake	F							F									
Drum Hoist	H							H										
08	BATTERY	C		C					O									
	Cables	C							O					O				
	Box, Battery	C							O					F				
09	AXLE, ASSEMBLIES	O							F		O							
	Kingpin	O							F									
	Guides, Kingpin	O							F									
	Tongue	O							F		F							
	Chain, Safety	C							O		F							
	Radii's Rods	O							O		F							
	Knuckles, Steering	O							F		F							
	Fifth Wheel	O							F		F							
	Axle, Rear	O							F									
10	WHEEL ASSY	O		O					O		(
	Hub Assy	O							O									
	Cones & Bearings	O		O					O									
	Seals, Grease	O							O									
	Tires & Tubes	C		C					O		F							

Section III. SPECIAL TOOL AND SPECIAL TEST EQUIPMENT REQUIREMENTS

Reference Code	Maintenance Category	Nomenclature	Tool Number
		None required	

**APPENDIX C
BASIC ISSUE ITEM LIST AND ITEMS
TROOP INSTALLED OR AUTHORIZED**

Section I. INTRODUCTION

C-1. Scope.

This appendix lists basic issue items, items troop installed or authorized which accompany the mixer, and required by the crew / operator for operation, installation, or operator's maintenance.

C-2. General

This basic issue items, items troop installed or authorized list is divided into the following sections:

a. *Basic Issue Items List-Section II.* A list, in alphabetical sequence, of items which are furnished with and which must be turned in with the end item.

b. *Items Troop Installed or Authorized List Section III.* A list, in alphabetical sequence of items which at the descretion of the unit commander may accompany the end item, but are NOT subject to be turned in with the end item.

C-3. Explanation of Columns

The following provides an explanation of columns in the tabular list of Basic Issue Items List, section II, and Items Troop Installed or Authorized, section III.

a. *Source, Maintenance, and Recoverability Code (is) (SMR):*

- (1) Source code, indicates the source for the listed item. Source codes are:

<i>Code</i>	<i>Explanation</i>
P	Repair parts, special tools and test equipment supplied from GSA/DSA or Army supply system and authorized for use at indicated maintenance levels.
P2	Repair parts, special tools and test equipment which are procured and stocked for insurance purposes because the combat or military essentiality of the end item dictates that a minimum quantity be available in the supply system.
	(2) Maintenance code, indicates the lowest level of maintenance authorized to install the li item. The maintenance level code is:

<i>Code</i>	<i>Explanation</i>
C	Crew Operator
(3)	Recoverability code, indicates whether unserviceable items should be returned for recovery or salvage. Items not coded are nonrecoverable. Recoverability codes are:

<i>Code</i>	<i>Explanation</i>
R	Applied to repair parts (assemblies and components), special tools and test equipment which are considered economically repairable at direct and general support maintenance levels.
S	Repair parts, special tools and test equipment and assemblies which are economically repairable at DSU and GSU activities and which normally are furnished by supply on an exchange basis.

b. Federal Stock Number. This column indicates the Federal Stock number assigned to the item and will be used for requisitioning purposes.

c. Description. This column indicates the Federal item name and any additional description of the item required.

d. Unit of Measure (U/M). A two-character alphabetic abbreviation indicating the amount or quantity of the item upon which the allowances are based, e.g., ft, pr, etc.

e. Quantity Furnished With Equipment (BIIL only). This column indicates the quantity of an item furnished with the equipment.

f. Quantity Authorized (Items Troop Installed or Authorized Only). This column indicates the quantity of the items authorized to be used with the equipment.

g. Illustration (BIIL only). This column is divided as follows:

- (1) Figure Number. Indicates the figure number of the illustration in which the item is shown.
- (2) Item Number. Indicates the callout number used to reference the item in the illustration.

Section II. BASIC ISSUE ITEMS

(1) SMR code	(2) Federal stock number	(3) Description Ref no. & mfg code Usable on code		(4) Unit of mes s	(5) Qty inc in unit	(6) Qty furn with equip	(7) Illustration	
							(A) Fig No.	(B) Item No.
PC	2990-906-7920	Hand Crank, Engine Starting. P/N U212R		EA	1	1	2-7	

Section III. ITEMS TROOP INSTALLED OR AUTHORIZED LIST

(1) SMR CODE	(2) FEDERAL STOCK NUMBER	(3) DESCRIPTION REF NO. & MFG CODE	(4) UNIT OF MEAS.	(5) QTY AUTH
	4210-889-2221	Extinguisher, Fire	EA	1
	4720-727-4224	Hose, Bulk; 1-1/4 In. 10X10 Ft.	EA	1
	4730-196-1533	Nipple, Pipe; 1-1/2 In. OD X 4 In.	EA	1
	4730-202-8968	Clamp	EA	1

Change 1 C-3/C-4 blank

INDEX

	Paragraph	Page	Paragraph	Page
A				
Adjustment			Fuel level sending unit.....	4-31 4-17
Belt			Fuel strainer	4-29 4-17
Pump.....	4-49	4-21	Fuel strainer service.....	3-8 3-4
Hoist, drive	4-1	4-1	Fuel tank	4-32 4-18
Carburetor.....	4-30	4-17	Feed tank service.....	3-7 3-3
Clutch.....	4-47	4-21	G	
Magneto	4-24	4-13	Gage, fuel level.....	4-42 4-20
Spark Plugs.....	4-25	4-15	Gage, oil pressure	4-43 4-20'
Valve tappets	4-14	4-8	Governor control	4-39 4-20
Air cleaner.....	4-28	4-15	H	
Ammeter	4-44	4-20	Hauling stub safety chain.....	4-53 4-23
B				
Batteries.....	3-10, 4-21	3-4, 4-12	Hi-temperature safety switch	4-26 4-13
Battery Box	4-22	4-12	Hoist cable	4-32 4-23
Belt, pump.....	4-49	4-21	Hour-meter tachometer	4-45 4-20
C				
Cables, battery	4-21	4-12	I	
Cable, hoist	4-52	4-23	Identification and instruction	
Chain, safety, hauling stub	4-53	4-23	plates	1-5 1-3
Cooling system, general	4-18	4-10	Ignition switch.....	4-40 4-20
Cylinder air shrouds.....	4-19	4-10	Interference suppression component...	4-8 4-6
D				
Description and data.....	1-3, 1-4, 1-5	1-1,1-3	Inspecting and servicing.	
Detailed lubrication.....	3-3	3-1	the equipment.....	2-1, 4-1 2-1, 4-1
Differences between models.....	1-4	1-3	L	
E				
Electrical system, general.....	4-20	4-11	Lower manifolds	4-17 4-10
Battery box	4-22	4-12	Lubrication instructions	
Batteries and cable	4-21	4-12	Detailed	3-3 3-1
Hi-temperature safety			General.....	3-2 3-1
switch	4-26	4-15	Lubrication system, general	4-33 4-18
Magneto	4-24	4-13	Oil filler cap	3-9, 4-35 3-4, 4-19
Starting motor.....	4-23	4-13	Oil filler tube strainer.....	4-36 4-19
Engine controls, meters and			Oil filter.....	4-34 4-18
gages, general	4-37	4-19	M	
Ammeter	4-4	4-20	Magneto	4-24 4- 13
Choke	4-38	4-19	Maintenance forms and records...	1-2 1-1
Fuel level gage	4-42	4-20	Maintenance repair part.....	4-4 4-3
Governor	4-39	4-20	Muffler.....	4-11 4-,
Hi-temperature safety			O	
switch	4-26	4-15	Oil filler cap.....	3-9, 4-33 3-4, 4-19,
Hour-meter tachometer.....	4-45	4-20	Oil filler tube strainer	4-36 4-19
Ignition switch	4-40	4-20	Oil filter	4-34 4-18
Oil pressure gage.....	4-43	4-20	Oil pressure gage	4-43 4-20
Start switch.....	4-41	4-20	Operation	
Engine top canopy, side			In dusty or sandy areas.....	2-13 2-5
doors and front panel	4-12	4-7	In extreme cold.....	2-11 2-5
F				
Flywheel and flywheel shroud....	4-13	4-17	In extreme heat.....	2-12 2-5
Fuel system, general	4-27	4-15	In high altitude	2-15 2-6
Fuel level gage.....	4-42	4-20	In humid conditions or in	
			salt water areas.....	2-14 2-5
			Operating the mixer.....	2-10 2-5
			Starting.....	2-8 2-4
			Stopping	2-9 2-4

	Paragraph	Page
P		
Preparation for movement.....	2-3	2-2
Preventive maintenance checks and services	3-4, 4-3	3-1, 4-3
Pump	4-50	4-22
Pump belt.....	4-49	4-21
R		
Radio interference suppression, general	4-7	4-6
Interference suppression components.....	4-8	4-6
Testing of interference suppression components.....	4-9	4-6
S		
Sending Unit fuel level	4-31	4-17
Service:		
Battery	3-10	3-4
Fuel strainer.....	3-8	3-4
Oil filler cap	3-9	3-4
Tire.....	3-11	3-5
Setting up instructions	2-2	2-1
At new work site.....	2-4	2-2
Preparation for movement	2-3	2-2
Spark plugs and leads	2-2	2-1
Special tools and equipment.....	4-3	4-3
Starting	2-8	2-4
Starting motor	4-23	4-13

	Paragraph	Page
Strainer, fuel.....	4-29	4-17
Stopping.....	2-9	2-4
Suppression components, radio interference.....	4-8	4-6
Switch, ignition	4-40	4-20
T		
Tabulated data	1-5	1-3
Tachometer, hour-meter.....	4-45	4-20
Tank, fuel	3-7, 4-32	3-3, 4-18
Testing of radio interference suppression components.....	4-9	4-6
Three-way valve.....	4-51	4-22
Tire service	3-11	3-5
Tools and equipment.....	4-2	4-3
Troubleshooting.....	3-5, 4-6	3-3, 4-5
U		
Upper manifolds	4-16	4-9
V		
Valve tappets	4-14	4-8
Valve, three-way, water	4 51	4-22
W		
Water pump	4-50	4-22
Water valve, three-way	4-51	4-22
Wheel assembly.....	4-54	4-25

By Order of the Secretary of the Army:

Official:

VERNE L. BOWERS,
*Major General, United State Army,
The Adjutant General.*

W. C. WESTMORELAND.
*General. United States Army.
Chief of Staff.*

Distribution:

To be distributed in accordance with DA Form 12-25B (qty rqr block No. 430) organizational maintenance requirements for Mixer, Concrete.

RECOMMENDED CHANGES TO EQUIPMENT TECHNICAL PUBLICATIONS

SOMETHING WRONG

WITH THIS PUBLICATION?



THEN . . . JOT DOWN THE DOPE ABOUT IT ON THIS FORM, FOLD IT, AND DROP IT IN THE MAIL!

FROM: (PRINT YOUR UNIT'S COMPLETE ADDRESS)

DATE SENT

PUBLICATION NUMBER

PUBLICATION DATE

PUBLICATION TITLE

BE EXACT . . . PIN-POINT WHERE IT IS

PAGE NO.	PARA-GRAPH	FIGURE NO.	TABLE NO.

IN THIS SPACE TELL WHAT IS WRONG AND WHAT SHOULD BE DONE ABOUT IT:

PRINTED NAME, GRADE OR TITLE, AND TELEPHONE NUMBER

SIGN HERE

THE METRIC SYSTEM AND EQUIVALENTS

WEIGHT MEASURE

1 Centimeter = 10 Millimeters = 0.01 Meters = 0.3937 Inches
 1 Meter = 100 Centimeters = 1000 Millimeters = 39.37 Inches
 1 Kilometer = 1000 Meters = 0.621 Miles

WEIGHTS

1 Gram = 0.001 Kilograms = 1000 Milligrams = 0.035 Ounces
 1 Kilogram = 1000 Grams = 2.2 lb.
 1 Metric Ton = 1000 Kilograms = 1 Megagram = 1.1 Short Tons

LIQUID MEASURE

1 Milliliter = 0.001 Liters = 0.0338 Fluid Ounces
 1 Liter = 1000 Milliliters = 33.82 Fluid Ounces

SQUARE MEASURE

1 Sq. Centimeter = 100 Sq. Millimeters = 0.155 Sq. Inches
 1 Sq. Meter = 10,000 Sq. Centimeters = 10.76 Sq. Feet
 1 Sq. Kilometer = 1,000,000 Sq. Meters = 0.386 Sq. Miles

CUBIC MEASURE

1 Cu. Centimeter = 1000 Cu. Millimeters = 0.06 Cu. Inches
 1 Cu. Meter = 1,000,000 Cu. Centimeters = 35.31 Cu. Feet

TEMPERATURE

$5/9(^{\circ}\text{F} - 32) = ^{\circ}\text{C}$
 212° Fahrenheit is equivalent to 100° Celsius
 90° Fahrenheit is equivalent to 32.2° Celsius
 32° Fahrenheit is equivalent to 0° Celsius
 $9/5^{\circ}\text{C} + 32 = ^{\circ}\text{F}$

APPROXIMATE CONVERSION FACTORS

TO CHANGE	TO	MULTIPLY BY
Inches	Centimeters	2.540
Feet	Meters	0.305
Yards	Meters	0.914
Miles	Kilometers	1.609
Square Inches	Square Centimeters	6.451
Square Feet	Square Meters	0.093
Square Yards	Square Meters	0.836
Square Miles	Square Kilometers	2.590
Acres	Square Hectometers	0.405
Cubic Feet	Cubic Meters	0.028
Cubic Yards	Cubic Meters	0.765
Fluid Ounces	Milliliters	29.573
its	Liters	0.473
arts	Liters	0.946
allons	Liters	3.785
Ounces	Grams	28.349
Pounds	Kilograms	0.454
Short Tons	Metric Tons	0.907
Pound-Feet	Newton-Meters	1.356
Pounds per Square Inch	Kilopascals	6.895
Miles per Gallon	Kilometers per Liter	0.425
Miles per Hour	Kilometers per Hour	1.609

TO CHANGE	TO	MULTIPLY BY
Centimeters	Inches	0.394
Meters	Feet	3.280
Meters	Yards	1.094
Kilometers	Miles	0.621
Square Centimeters	Square Inches	0.155
Square Meters	Square Feet	10.764
Square Meters	Square Yards	1.196
Square Kilometers	Square Miles	0.386
Square Hectometers	Acres	2.471
Cubic Meters	Cubic Feet	35.315
Cubic Meters	Cubic Yards	1.308
Milliliters	Fluid Ounces	0.034
Liters	Pints	2.113
Liters	Quarts	1.057
ers	Gallons	0.264
ms	Ounces	0.035
ograms	Pounds	2.205
Metric Tons	Short Tons	1.102
Newton-Meters	Pounds-Feet	0.738
Kilopascals	Pounds per Square Inch	0.145
ometers per Liter	Miles per Gallon	2.354
ometers per Hour	Miles per Hour	0.621



PIN: 025355-002